

Some Equation of State Modules for TOUGH3

Table of Contents

EOS1.....	1
EOS2.....	23
EOS3.....	31
EOS4.....	45
EOS5.....	58
EOS7.....	65
EOS7R.....	76
EOS8.....	96
EOS9.....	105
EWASG.....	121

For ECO2N, ECO2M, EOS7C, EOS7CA, and TMVOC, see stand-alone reports.

EOS1: An Equation-of-State Module for Water, Water with Tracer

Yoojin Jung
George Pau
Stefan Finsterle

Earth Sciences Division, Lawrence Berkeley National Laboratory
University of California, Berkeley, California 94720

1. Description

This is the most basic EOS module, providing a description of pure water in its liquid, vapor, and two-phase states. All water properties (density, specific enthalpy, viscosity, saturated vapor pressure) are calculated from the steam table equations as given by the International Formulation Committee (1967). The formulation includes subregion 1 (subcooled water below $T = 350$ °C), subregion 2 (superheated steam), and subregion 6 (saturation line up to $T = 350$ °C). In these regions, density and internal energy are represented within experimental accuracy. Viscosity of liquid water and steam are represented to within 2.5 % by correlations given in the same reference. For details of the formulation, its accuracy and range of validity, refer to the original publication. Vapor pressure lowering from capillary and adsorption effects is neglected; thus, in two-phase conditions vapor pressure is equal to saturated vapor pressure of bulk liquid.

2. Specifications

A summary of EOS1 specifications and parameters is given in Table 1. The default parameter settings are $(NK, NEQ, NPH, NB) = (1, 2, 2, 6)$ for solving mass and energy balances for a single water component. The option $NEQ = 1$ is available for running single-phase flow problems that involve only liquid water, or only superheated steam, under constant temperature conditions. EOS1 also has a capability for representing two waters of identical physical properties, which contain different trace constituents. This option can be invoked by specifying $(NK, NEQ, NPH, NB) = (2, 3, 2, 6)$ in data block **MULTI**. With this option, two water mass balances will be set up, allowing separate tracking of the two components. For example, one could specify the water initially present in the flow system as “water 1,” while water being injected is specified as “water 2.” When the two waters option is chosen, molecular diffusion can also be modeled by setting parameter NB equal to 8.

The primary variables are (P, T) for single-phase points, (P_g, S_g) for two-phase points. For the convenience of the user it is possible to initialize two-phase points as (T, S_g) ; when the numerical value of the first primary variable is less than 374.15, this will automatically be taken to indicate that this represents temperature rather than pressure, and will cause variables to be converted internally from (T, S_g) to $(P_{sat}(T), S_g)$ prior to execution. When the two waters option is used, primary variables are (P, T, X) for single-phase points, and (P_g, S_g, X) for two-phase points, where X is the mass fraction of “water 2” present. All thermophysical properties (density, specific enthalpy, viscosity) are assumed independent of the component mixture; i.e.,

independent of mass fraction X . This approximation is applicable for problems in which the identity of different waters is distinguished by the presence of different trace constituents, which occur in concentrations low enough to not appreciably affect the thermophysical properties.

Table 1. Summary of EOS1

<u>Components</u>	# 1: water # 2: “water 2” (optional)
<u>Parameter choices</u> $(NK, NEQ, NPH, NB) =$	(1, 2, 2, 6) one water component, nonisothermal (default) (1, 1, 2, 6) only liquid, or only vapor; isothermal (2, 3, 2, 6) two-waters, nonisothermal*
molecular diffusion can be modeled by setting $NK = 2, NB = 8$	
<u>Primary Variables</u>	
single-phase conditions	$(P, T, [X])$ - (pressure, temperature, [mass fraction of water 2] [†])
two-phase conditions	$(P_g, S_g, [X])$ - (gas phase pressure, gas saturation, [mass fraction of water 2] [†])

* two waters cannot be run in isothermal mode, because in this case temperature is not the last primary variable

† optional, for $NK = 2$ only

The phase diagnostic procedures are as follows. When initializing a problem, each grid block has two primary variables ($X1, X2$). The meaning of $X2$ depends on its numerical value: for $X2 > 1.5$, $X2$ is taken to be temperature in °C, otherwise it is gas saturation. Although physically saturation is restricted to the range $0 \leq S \leq 1$, it is necessary to allow saturations to exceed 1 during the Newton-Raphson iteration. If $X2$ is temperature, this indicates that single-phase conditions are present; specifically, for $P (= X1) > P_{sat}(T)$ we have single-phase liquid, otherwise we have single-phase steam. Subsequent to initialization, the phase condition is identified simply based on the value of S_g as stored in the PAR array. $S_g = 0$: single-phase liquid, $S_g = 1$: single-phase vapor, $0 < S_g < 1$: two-phase.

Phase change is recognized as follows. For single-phase points the temperature (second primary variable) is monitored, and the corresponding saturation pressure is compared with actual fluid pressure P . For a vapor (liquid) point to remain vapor (liquid), we require that $P < P_{sat}$ ($P > P_{sat}$); if this requirement is violated, a transition to two-phase conditions takes place. The primary variables are then switched to (P_g, S_g) , and these are initialized as $P_g = P_{sat}(T)$, $S_g = 0.999999$ if the point was in the vapor region, and $S_g = 0.000001$ if it was in the liquid region. For two-phase points S_g is monitored; we require that $0 < S_g < 1$ for a point to remain two-phase. If $S_g < 0$ this indicates disappearance of the gas phase; the primary variables are then switched to (P, T) , and the point is initialized as single-phase liquid, with T taken from the last Newton-Raphson iteration, and $P = 1.000001 \times P_{sat}(T)$. For $S_g > 1$ the liquid phase disappears; again the primary variables are switched to (P, T) , and the point is initialized as single-phase vapor, with T taken from the last Newton-Raphson iteration, and $P = 0.999999 \times P_{sat}(T)$. Note that in these phase transitions we preserve temperature rather than pressure from the last iteration. This is preferable because in most flow problems temperature tends to be more slowly varying than pressure.

3. Sample Problems

3.1. Problem No. 1 (*eos1p1*) - Code Demonstration

This problem demonstrates various initialization options and phase transitions. A number of one- and two-element subproblems are simulated which are entirely independent of each other (no flow connections between subproblems), except that being run together they all must go through the same sequence of time steps. The standard method for initialization is used for “F 1”, “F 2”, and “F 5” in single-phase liquid conditions and for “F 3” in two-phase condition. “F 4” is initialized with two-phase type primary variables, but with temperature for the first primary variable. Data block **OUTPU** is used to select variables to print out, and data blocks **FOFT** and **GOFT** are used to generate time series for selected grid blocks and generation items that can be used for plotting. Figure 1 shows the input file, and Figure 2 gives the printed output in the CSV format.

```

*eos1p1* CODE DEMONSTRATION: PHASE TRANSITIONS
ROCKS----1----*----2----*----3----*----4----*----5----*----6----*----7----*----8
TRANS          2650.          .50    1.E-14          2.10    1000.

START----1----*----2----*----3----*----4----*----5----*----6----*----7----*----8
-----1 MOP: 123456789*123456789*1234 -----5----*----6----*----7----*----8
PARAM----1----*----2----*----3----*----4----*----5----*----6----*----7----*----8
      2    5          1100 30 000000000711
              -1.
            1.E-8      1.E2      5.E3
                  1.E5                  20.

RPCAP----1----*----2----*----3----*----4----*----5----*----6----*----7----*----8
      3          .30          .05
      1          1.
ELEME ---1----*----2----*----3----*----4----*----5----*----6----*----7----*----8
F  1    4    1TRANS      10.

CONNE ---1----*----2----*----3----*----4----*----5----*----6----*----7----*----8
F  1F  2          1      5.      5.      1.
F  3F  4          1      5.      5.      1.

INCON ---1----*----2----*----3----*----4----*----5----*----6----*----7----*----8
F  1
      1.E5          20.
F  2
      1.E6          170.
F  3
      1.E5          .001
F  4
      310.          .999
F  5
      1.E7          300.

GENER ---1----*----2----*----3----*----4----*----5----*----6----*----7----*----8
F  5WEL 1          MASS    -1.5E-2

FOFT ---1----*----2----*----3----*----4----*----5----*----6----*----7----*----8
F  5

GOFT ---1----*----2----*----3----*----4----*----5----*----6----*----7----*----8
F  5WEL 1          -1

OUTPU---1----*----2----*----3----*----4----*----5----*----6----*----7----*----8
      3
PRESSURE
TEMPERATURE
SATURATION          2

ENDCY---1----*----2----*----3----*----4----*----5----*----6----*----7----*----8

```

Figure 1. Input file for problem eos1p1.

"	ELEM", "	PRES_G", "	TEMP", "	SAT_L"
"	", "	(PA)", "	(DEC-C)", "	(-)"
"TIME [sec]	0.10000000E-07"			
"	F0001",	0.100000000000E+06,	0.200000000000E+02,	0.100000000000E+01
"	F0002",	0.100000000000E+07,	0.170000000000E+03,	0.100000000000E+01
"	F0003",	0.100000000000E+06,	0.996316340349E+02,	0.999000000000E+00
"	F0004",	0.987001171518E+07,	0.310000000000E+03,	0.100000000000E-02
"	F0005",	0.100000000000E+08,	0.300000000000E+03,	0.100000000000E+01
"TIME [sec]	0.10000000E+03"			
"	F0001",	0.263681121349E+06,	0.200083094599E+02,	0.100000000000E+01
"	F0002",	0.872045624615E+06,	0.169990013607E+03,	0.100000000000E+01
"	F0003",	0.100325131219E+06,	0.997223791790E+02,	0.999341811454E+00
"	F0004",	0.985625294546E+07,	0.309897743901E+03,	0.734124020746E-03
"	F0005",	0.981069891971E+07,	0.299948522719E+03,	0.100000000000E+01
"TIME [sec]	0.51000000E+04"			
"	F0001",	0.755280088026E+06,	0.200375060824E+02,	0.100000000000E+01
"	F0002",	0.791615866285E+06,	0.169978747129E+03,	0.999802280762E+00
"	F0003",	0.817775100379E+07,	0.101245269222E+03,	0.100000000000E+01
"	F0004",	0.952274695399E+07,	0.309151522236E+03,	0.000000000000E+00
"	F0005",	0.852058902400E+07,	0.299402295980E+03,	0.979977480184E+00
"TIME [sec]	0.30100000E+05"			
"	F0001",	0.790786436927E+06,	0.200619140337E+02,	0.100000000000E+01
"	F0002",	0.791155909440E+06,	0.169954709576E+03,	0.999762553094E+00
"	F0003",	0.943704686898E+07,	0.101478156690E+03,	0.100000000000E+01
"	F0004",	0.947112159139E+07,	0.309004271627E+03,	0.000000000000E+00
"	F0005",	0.838056981056E+07,	0.298230438530E+03,	0.864723913029E+00
"TIME [sec]	0.83773991E+05"			
"	F0001",	0.791147671477E+06,	0.201114019414E+02,	0.100000000000E+01
"	F0002",	0.790151949372E+06,	0.169902203704E+03,	0.999714151369E+00
"	F0003",	0.946837989727E+07,	0.101549355859E+03,	0.100000000000E+01
"	F0004",	0.946740829373E+07,	0.308813033393E+03,	0.000000000000E+00
"	F0005",	0.572908606823E+07,	0.272552497144E+03,	0.592172560057E+00

Figure 2. Printed output variables in CSV format based on **OUTPU** block shown in Figure 1.

3.2.Problem No. 2 (*rvf*) - Heat Sweep in a Vertical Fracture

In many geothermal fields there is evidence of rapid migration of injected fluids along preferential flow paths, presumably along fractures. The present problem is designed to study thermal interference along such paths, by modeling nonisothermal injection into and production from a single vertical fracture, as illustrated in Figure 3 (from Pruess and Bodvarsson, 1984). The fracture is bounded by semi-infinite half-spaces of impermeable rock, which provide a conductive heat supply. Initial temperature is 300 °C throughout. Water at 100 °C temperature is injected at one side of the fracture at a constant rate of 4 kg/s, while production occurs at the other side against a specified wellbore pressure. Problem parameters are given in Table 2, and the TOUGH3 input file for injecting at point *I* and producing at point *P* is shown in Figure 4.

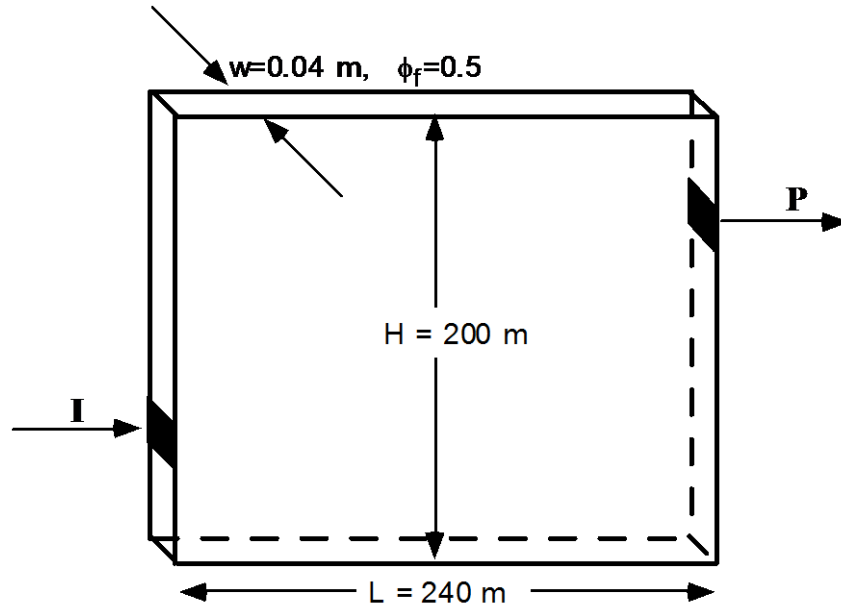

Figure 3. Schematic diagram of injection-production system in vertical fracture. Injection occurs at I, production at P.

A special feature of the problem is that the semi-analytical method is used to describe heat conduction in the confining layers (see section 4.4 in TOUGH3 User's Guide), reducing the dimensionality of the problem from 3-D to 2-D. This feature is invoked by setting $MOP(15) = 1$. Water remains in single-phase liquid conditions throughout, so that no data block **RPCAP** for relative permeabilities and capillary pressures is needed.

The input file as given in Figure 4 includes a **SOLVR** data block, selecting the stabilized bi-conjugate gradient solver **DLUSTB** ($MATSLV = 5$) with **Z1** preconditioning. Other solvers could be used for this problem, but the particular solver and preconditioner combination was chosen because it is robust enough to be able to handle a "two waters" variation of the problem.

The problem is run in three separate segments. A first run performs mesh generation only, using the **MESHMAKER/XYZ** module. For this run, the data records from **MESHM** through **ENDEFI** in the input file are inserted right behind the first record with the problem title. The mesh consists of 12 horizontal by 10 vertical blocks of 20 m x 20 m. Ordinarily, we would specify $NX = 12$ and $NZ = 10$ to make such a mesh; however, special considerations arise here because we desire appropriate surface areas for heat conduction to be placed in the **MESH** file. By default, in

the MESHMaker/XYZ module the interface areas with impermeable confining beds are always taken to be in the X-Y plane, so that in a mesh with vertical Z-axis the interface areas for conductive heat transfer would be assigned to the top and bottom boundaries. To properly assign the desired lateral heat transfer areas, the mesh is generated as an X-Y mesh ($NX = 12$, $NY = 10$, $NZ = 1$), and the Y-axis is specified to make an angle of 90° with the horizontal, i.e., to point in the vertical direction. The MESHMAKER input terminates on **ENDFI**, to bypass the flow simulation and to limit processing to mesh generation only.

Table 2. Parameters for fracture flow problem

Rock	
Thermal conductivity	2.1 W/m°C
Specific heat	1000 J/kg°C
Density	2650 kg/m ³
Permeability	0
Fracture	
Height	200 m
Length	240 m
Aperture	0.04 m
Permeability	200x10 ⁻¹² m ² (200 darcy)
Porosity	50 %
Initial Conditions	
Temperature	300 °C
Pressure	hydrostatic profile
Average pressure	100 bar
Injection	
Enthalpy	4.2x10 ⁵ J/kg (appr.100 °C)
Rate	4 kg/s
Production	
Productivity index	4 x10 ⁻¹² m ³
Flowing pressure	96.5 bar

```

*****
*                                     CARTESIAN MESH WITH NX*NY*NZ =      12 *
*****
*
*                                     THE MESH WILL BE PRINTED AS SLICES FOR
*
*                                     IN EACH MESH SLICE, ROWS WILL GO FROM
*
*                                     IN EACH ROW, COLUMNS WILL GO FROM
*
*****
SLICE WITH K =      1
  COLUMN I =      1      2      3      4      5      6      7      8
R O W S
=      1      A11 1 1  A11 1 2  A11 1 3  A11 1 4  A11 1 5  A11 1 6  A11 1 7  A11 1 8
J J J =      2      A11 2 1  A11 2 2  A11 2 3  A11 2 4  A11 2 5  A11 2 6  A11 2 7  A11 2 8
J J J =      3      A11 3 1  A11 3 2  A11 3 3  A11 3 4  A11 3 5  A11 3 6  A11 3 7  A11 3 8
J J J =      4      A11 4 1  A11 4 2  A11 4 3  A11 4 4  A11 4 5  A11 4 6  A11 4 7  A11 4 8
J J J =      5      A11 5 1  A11 5 2  A11 5 3  A11 5 4  A11 5 5  A11 5 6  A11 5 7  A11 5 8
J J J =      6      A11 6 1  A11 6 2  A11 6 3  A11 6 4  A11 6 5  A11 6 6  A11 6 7  A11 6 8
J J J =      7      A11 7 1  A11 7 2  A11 7 3  A11 7 4  A11 7 5  A11 7 6  A11 7 7  A11 7 8
J J J =      8      A11 8 1  A11 8 2  A11 8 3  A11 8 4  A11 8 5  A11 8 6  A11 8 7  A11 8 8
J J J =      9      A11 9 1  A11 9 2  A11 9 3  A11 9 4  A11 9 5  A11 9 6  A11 9 7  A11 9 8
J      =     10      A1A  1  A1A  2  A1A  3  A1A  4  A1A  5  A1A  6  A1A  7  A1A  8
*****
MESH GENERATION COMPLETE --- EXIT FROM MODULE *MESHPAKER*

```

Figure 5. TOUGH3 printout of mesh pattern in problem 2.

The next processing step calculates a hydrostatic pressure equilibrium in the fracture under isothermal conditions. This calculation uses the modified MESH file obtained above, and requires several small modifications in the input file of Figure 4. The time step counter *MCYC* is changed from 40 to 4, as 4 time steps are sufficient to obtain an accurate gravity equilibrium. The generation items are removed, and the convergence tolerance *RE1* is changed from 1×10^{-5} to 1×10^{-8} , to achieve a tighter control on gravity equilibrium. The **ENDCY** statement preceding the **INCON** record is removed, to enforce default initial conditions by way of an empty **INCON** data block, and to engage the **MULTI** data block with specifications of $(NK, NEQ, NPH, NB) = (1, 1, 2, 6)$ for an isothermal calculation (mass balance only). We also set $MOP(15) = 0$, to disengage the semi-analytical heat exchange calculation. Gravity equilibration results in a pressure trend ranging from 106.34175 bars in the bottom row of grid blocks (A1A 1, A1A 2, ..., A1A12), to 93.70950 bars in the top row (A11 1, ..., A1112).

The subsequent production/injection run uses the input file exactly as given in Figure 4, with the MESH file as used in the gravity equilibration. The SAVE file produced by the gravity equilibration run is renamed file **INCON** and used for initialization, after removing the last two records and replacing them with a blank record, to reset time-step and simulation time counters to zero. The specified maximum time of 1.57788×10^8 seconds (5 years) is reached after 37 time steps; at this time production occurs with a rate of 3.9998 kg/s and an enthalpy of 870.31 kJ/kg;

temperature in the producing element is 203.25 °C. Figure 6 shows a contour plot of the temperature distribution in the fracture after 5 years, and a plot of the transient temperature changes at the producing element is given in Figure 7.

The fracture production/injection problem lends itself to several interesting extensions and variations. These can be implemented by means of small modifications in the input file and are mentioned here without giving calculation results. For example, the problem could be restarted with a zero injection rate to examine the rate of temperature recovery in the production block. Initial conditions could be chosen appropriate for depleted zones in vapor-dominated reservoirs, e.g., $T = 240$ °C, $P = 8$ bars, to examine injection response with strong vaporization effects. Note that for injection into vapor-dominated systems, two-phase conditions will evolve and a data block **RPCAP** with relative permeability and capillary pressure data will be required. We point out that strong grid orientation effects may arise when modeling water injection into vapor-dominated reservoirs and careful mesh design or inclusion of diffusive effects (capillary pressures) is required to obtain realistic results (Pruess, 1991).

The problem can be run using “two waters” by specifying a **MULTI** data block with parameters $(NK, NEQ, NPH, NB) = (2, 3, 2, 6)$, along with injection type *COM2* instead of *COM1*, to inject “water 2” and thereby track the advance and arrival of injected water at the production point. The input file as shown in Figure 4 has appropriate data records at the end for running as a two waters problem. The particular selection of solver and preconditioner in this problem was made to be able to cope with the many zeros that will arise on the main diagonal of the Jacobian matrix for the two waters variation. The problem could also be run with the EOS2 fluid property module, with some CO₂ initially present in the reservoir fluid, to study the changes in non-condensable gas content of produced fluids in response to injection.

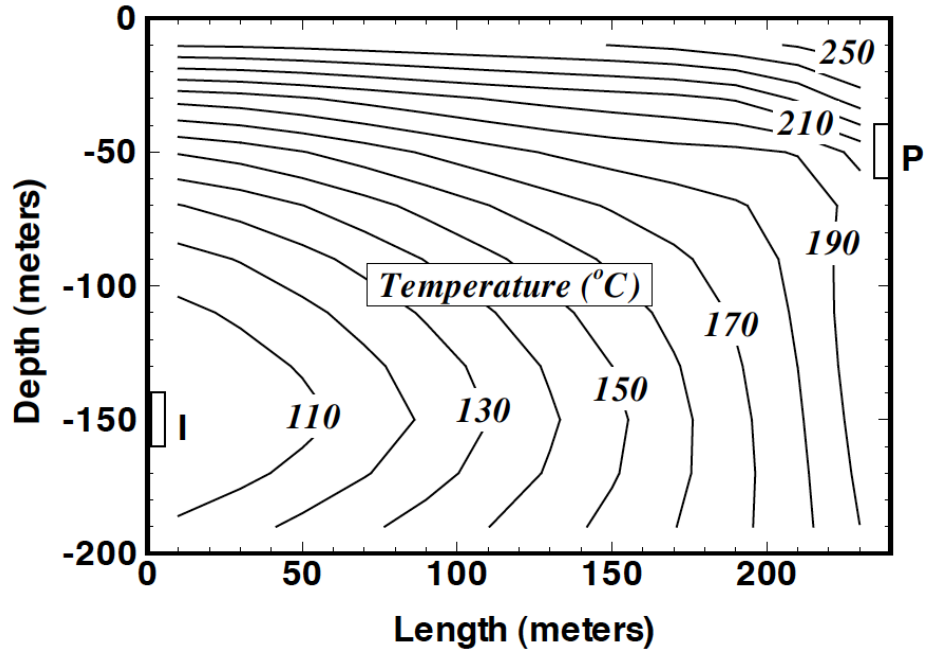

Figure 6. Temperature distribution in fracture plane after 5 years. Injection and production regions are marked I and P, respectively.

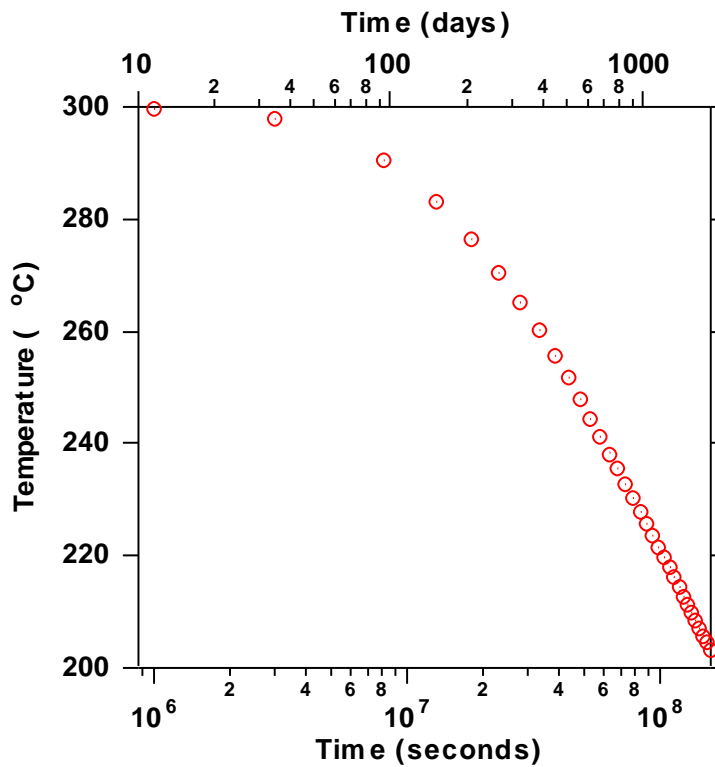

Figure 7. Produced fluid temperature versus time for vertical fracture problem.

3.3.Problem No. 3 (*rfp*) - Five-spot Geothermal Production/Injection

In geothermal reservoir development, production and injection wells are often sited in more or less regular geometric patterns. The present problem considers a large well field with wells arranged in a “five-spot” configuration (Figure 8). Because of symmetry only 1/8 of the basic pattern needs to be modeled. The computational grid was generated by means of a separate preprocessor program which has not yet been integrated into the TOUGH3 package. The grid has six rows, each containing between one and eleven elements, for a total of thirty-six volume elements; for simplicity, only a single layer of 305 m thickness is modeled. The problem specifications as given in Table 3 correspond to conditions that may typically be encountered in deeper zones of hot and fairly tight fractured two-phase reservoirs (Pruess and Narasimhan, 1985).

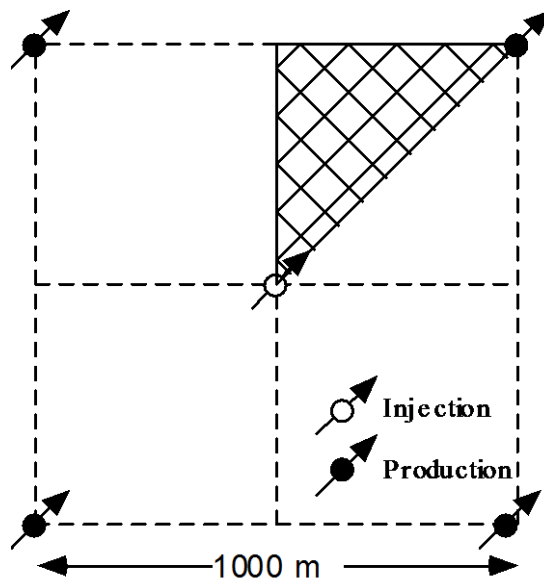

Figure 8. Five-spot well pattern with grid for modeling a 1/8 symmetry domain.

The input file in Figure 9 models the system as a fractured medium with embedded impermeable matrix blocks in the shape of cubes. The matrix blocks were assigned a non-vanishing porosity of 10^{-10} , so that they will contain a small amount of water. This has no noticeable impact on fluid and heat flows, and is done to prevent the water mass balance

equation from degenerating into the singular form $0 = 0$. Running the problem with $\phi = 0$ in the matrix blocks (domain `MATRIX`) is also possible, but this results in more sluggish convergence and considerably smaller time steps. The `MESHMAKER` module is used to perform MINC-partitioning of the primary grid (partition type `THRED` with three equal fracture spacings). The first MINC continuum, corresponding to the fracture domain, occupies a volume fraction of 0.02 and has an intrinsic porosity of 50 %, for an effective fracture porosity of 1 %. By inserting an `ENDCY` record in front of the `MESHM` data block, the MINC process can be disabled and the problem can be run as an effective porous medium. Figure 10 and Figure 11 show part of the printout of the MINC simulation run, and

Figure 12 gives temperature profiles along the line connecting the injection and production wells after 36.5 years. It is seen that the MINC results for 50 m fracture spacing are virtually identical to the porous medium results, while another MINC run for 250 m fracture spacing shows lower temperatures, indicating a less complete thermal sweep.

Table 3. Parameters for five-spot problem

Formation	
Rock grain density	2650 kg/m ³
Specific heat	1000 J/kg °C
Heat conductivity	2.1 W/m °C
Permeable volume fraction	2%
Porosity in permeable domain	50%
Impermeable blocks: cubes with side length	50m, 250 m
Permeability	6.0x10 ⁻¹⁵ m ²
Thickness	305 m
Relative permeability: Corey curves	
irreducible liquid saturation	0.30
irreducible gas saturation	0.05
Initial Conditions	
Temperature	300 °C
Liquid saturation	0.99
Pressure	85.93 bar
Production/Injection	
Pattern area	1 km ²
Distance between producers and injectors	707.1 m
Production rate*	30 kg/s
Injection rate*	30 kg/s
Injection enthalpy	500 kJ/kg

* Full well basis

```

* r f p *   - 3 6   B L O C K S   P A R A L L E L   F I V E - S P O T   G R I D   ( C F .   S
ROCKS  - - - - 1 - - - - * - - - - 2 - - - - * - - - - 3 - - - - * - - - - 4 - - - - * - - - -
POMED          2 6 5 0 .                . 0 1          6 . E - 1 5          6 . E -
FRACT          2 6 5 0 .                . 5 0          6 . E - 1 5          6 . E -
MATRX          2 6 5 0 .                1 . E - 1 0          0 . E - 1 5          0 . E -

START  - - - - 1 - - - - * - - - - 2 - - - - * - - - - 3 - - - - * - - - - 4 - - - - * - - - -
- - - - * - - - - 1   M O P :   1 2 3 4 5 6 7 8 9 * 1 2 3 4 5 6 7 8 9 * 1 2 3 4 - - - - * - - - -
PARAM  - - - - 1 - - - - * - - - - 2 - - - - * - - - - 3 - - - - * - - - - 4 - - - - * - - - -
    1      9 9          9 9 0 0 0 0 0 0 0 0 0 0 0 0 0 0 0 0 0 0 0 0 4 0
          1 . 1 5 1 8 5 2 E 9          - 1 .   3 . 1 5 5 7 6 E 7   K A   1
          1 . E 5
          1 . E - 5
          3 0 0 .                0 . 0 1
RPCAP  - - - - 1 - - - - * - - - - 2 - - - - * - - - - 3 - - - - * - - - - 4 - - - - * - - - -
    3          . 3 0          . 0 5
    1          1 .
TIMES  - - - - 1 - - - - * - - - - 2 - - - - * - - - - 3 - - - - * - - - - 4 - - - - * - - - -
    2          2
    1 . 5 7 7 8 8 E 8   7 . 8 8 9 4 0 E 8
GENER  - - - - 1 - - - - * - - - - 2 - - - - * - - - - 3 - - - - * - - - - 4 - - - - * - - - -
AA 1 I N J   1          M A S S          3 .
KA 1 P R O   1          M A S S          - 3 .

E L E M E - - - - 1 - - - - * - - - - 2 - - - - * - - - - 3 - - - - * - - - - 4 - - - - * - - - -
AA 1          P O M E D 0 . 1 9 0 6 E + 0 6 0 . 1 2 5 0 E + 0 4
BA 1          P O M E D 0 . 7 6 2 5 E + 0 6 0 . 5 0 0 0 E + 0 4
CA 1          P O M E D 0 . 7 6 2 5 E + 0 6 0 . 5 0 0 0 E + 0 4
DA 1          P O M E D 0 . 7 6 2 5 E + 0 6 0 . 5 0 0 0 E + 0 4
EA 1          P O M E D 0 . 7 6 2 5 E + 0 6 0 . 5 0 0 0 E + 0 4
FA 1          P O M E D 0 . 7 6 2 5 E + 0 6 0 . 5 0 0 0 E + 0 4
GA 1          P O M E D 0 . 7 6 2 5 E + 0 6 0 . 5 0 0 0 E + 0 4
HA 1          P O M E D 0 . 7 6 2 5 E + 0 6 0 . 5 0 0 0 E + 0 4
IA 1          P O M E D 0 . 7 6 2 5 E + 0 6 0 . 5 0 0 0 E + 0 4
JA 1          P O M E D 0 . 7 6 2 5 E + 0 6 0 . 5 0 0 0 E + 0 4
KA 1          P O M E D 0 . 1 9 0 6 E + 0 6 0 . 1 2 5 0 E + 0 4
BB 1          P O M E D 0 . 7 6 2 5 E + 0 6 0 . 5 0 0 0 E + 0 4
CB 1          P O M E D 0 . 1 5 2 5 E + 0 7 0 . 1 0 0 0 E + 0 5
. . .
. . .
GE 1          P O M E D 0 . 7 6 2 5 E + 0 6 0 . 5 0 0 0 E + 0 4
FF 1          P O M E D 0 . 3 8 1 2 E + 0 6 0 . 2 5 0 0 E + 0 4
HTX 0 0          P O M E D          0 .

CONNE  - - - - 1 - - - - * - - - - 2 - - - - * - - - - 3 - - - - * - - - - 4 - - - - * - - - -
AA 1 BA 1          1 0 . 3 5 3 6 E + 0 2 0 . 3 5 3 6 E +
BA 1 CA 1          1 0 . 3 5 3 6 E + 0 2 0 . 3 5 3 6 E +
BA 1 BB 1         2 0 . 3 5 3 6 E + 0 2 0 . 3 5 3 6 E +
CA 1 DA 1          1 0 . 3 5 3 6 E + 0 2 0 . 3 5 3 6 E +
. . .
. . .
FE 1 GE 1          1 0 . 3 5 3 6 E + 0 2 0 . 3 5 3 6 E +
FE 1 FF 1         2 0 . 3 5 3 6 E + 0 2 0 . 3 5 3 6 E +

INCON  - - - - 1 - - - - * - - - - 2 - - - - * - - - - 3 - - - - * - - - - 4 - - - - * - - - -

MESHMAKER 1 - - - - * - - - - 2 - - - - * - - - - 3 - - - - * - - - - 4 - - - - * - - - -
MINC
PART THRED          DFLT
    5    4 OUT          5 0 .
          . 0 2          . 0 8          . 2 0          . 3 5

ENDCY  - - - - 1 - - - - * - - - - 2 - - - - * - - - - 3 - - - - * - - - - 4 - - - - * - - - -

```

Figure 9. Input file for problem 3 - five-spot production/injection.

```

*****
*                               MESHMAKER - MINC: GENERATE MULTIPLE INTER
*****
FILE *MINC* EXISTS --- OPEN AS AN OLD FILE
CHOICE OF MATRIX-MATRIX FLOW HANDLING: "DFLT "
                                THE OPTIONS ARE: "          " (DEFAULT), NO
                                                "MMVER"; GLOBAL MATRI
                                                "MMALL"; GLOBAL MATRI

===== GEOMETRY DATA, NORMALIZED TO A DOMAIN O

CONTINUUM      IDENTIFIER          VOLUME          NODAL DISTANCE

1-FRACTURES    * *                .20000E-01       .00000E+00
2-MATRIX       * 2 *                .80000E-01       .34984E+00
3-MATRIX       * 3 *                .20000E+00       .97637E+00
4-MATRIX       * 4 *                .35000E+00       .23051E+01
5-MATRIX       * 5 *                .35000E+00       .35475E+01

=====
READ PRIMARY MESH FROM FILE *MESH*
      THE PRIMARY MESH HAS      37 ELEMENTS (      36 ACTIVE)
WRITE SECONDARY MESH ON FILE *MINC*
      THE SECONDARY MESH HAS     181 ELEMENTS (     180 ACTIVE)
*****
MESH GENERATION COMPLETE --- EXIT FROM MODULE *MESHMAKER*

```

Figure 10. Output from MINC processing for problem 3.

We mention again a number of problem variations that can be implemented with small modifications in the input file. For example, heat exchange with confining beds can be studied by setting $MOP(15) = 1$ (an appropriate inactive element to represent thermal parameters has already been included in the input file). This would be expected to be of minor significance for the porous medium and the $D = 50$ m fracture spacing cases, but could have major effects when fracture spacing is as large as 250 m. The problem could be run with permeable matrix blocks; typical matrix permeabilities in fractured geothermal reservoirs are of the order of 1 to 10 microdarcies (10^{-18} to 10^{-17} m²). It would also be of interest to compare a “production only” case with various different injection scenarios. The input file as is can also be run with the EOS2 module; the third primary variable would then specify a CO₂ partial pressure of 5 bars.

3.4.Problem No. 4 (*r1q*) - Coupled Wellbore Flow

Application of TOUGH3 to coupled reservoir-wellbore flow is demonstrated with a geothermal production problem similar to Problem 1 of Hadgu et al. (1995). An exact replication of their test problem is not possible because they did not give complete specifications in their paper. A well of 0.2 m inside diameter produces from a 500 m thick two-phase reservoir containing water at initial conditions of $P = 60$ bars, $T = T_{sat}(P) = 275.5$ °C, $S_g = 0.1$. Wellhead pressure is 7 bars, and feed zone depth is 1000 m.

The input file in Figure has MESHMaker data for a 1-D radial grid with a wellblock radius of 100 m, as used by Hadgu et al. (1995) to represent a large negative skin factor. The grid extends to a radius of 10,000 m and will be infinite-acting for the time period simulated. Prior to the flow simulation the grid is edited and the first (wellblock) nodal distance is set to a small value; for convenience the original connection record is provided at the end of the input file. In the flow simulation we specify a generation type `£725d` to engage coupled reservoir-wellbore flow using the flowing bottomhole well pressure data file `£725d` shown in Table 4 and Figure 14. Well productivity index is $4.64e-11$ m³, as used by Hadgu et al. (1995). We also include **FOFT** and **GOFT** data blocks to generate data files of time-dependent simulation results suitable for plotting.

The simulation starts with a time step of $1.e5$ seconds. Time steps grow rapidly, and the desired simulation time of 10^9 seconds is reached after 30 time steps. Part of the printed output is given in Figure 15, while Figure 16 shows the temporal evolution of well flow rate, flowing enthalpy, flowing bottomhole pressure, and wellblock pressure. By replacing the **GENER**-item in the input file with the *DELV* item included after the **ENDCY**-record (see Figure 13), a problem variation can be run in which production occurs on deliverability against a fixed bottomhole pressure of $P_{wb} = 57.37$ bars, which is the flowing bottomhole pressure in the coupled reservoir-wellbore system at the end of the first time step ($1.e5$ seconds). Results obtained for this case are also shown in Figure 16 and are marked with a subscript “c”.

Our results for flow rates and flowing enthalpies in the coupled model are a few percent higher than those obtained by Hadgu et al. (1995), while flowing bottomhole pressures are slightly lower. The simulation with constant bottomhole pressure gives a rapidly declining production rate that agrees well with Hadgu et al. (1995). It is seen that the coupled reservoir-wellbore system sustains long-term production at substantially higher rates, because it predicts a stronger rise in flowing enthalpy, for which wellbore flow can be sustained at smaller

bottomhole driving pressures. The large differences when compared with the simulation with constant bottomhole pressure emphasize the importance of coupled wellbore flow effects for two-phase geothermal production wells.

```

* r1q* --- 1-D radial test problem for flowing wellbo
MESHMAKER1-----*-----2-----*-----3-----*-----4-----*-----5--
RZ2D
RADI I
  2
      0 .          100 .
EQUID
  20              10 .
LOGAR
  30              1 .E 3
LOGAR
  30              1 .E 4
EQUID
  1                0 .0
LAYER-----1-----*-----2-----*-----3-----*-----4-----*-----5--
  1
      500 .

ENDFI-----1-----*-----2-----*-----3-----*-----4-----*-----5--
ROCKS-----1-----*-----2-----*-----3-----*-----4-----*-----5--
POMED              2600 .          .10          1 .e-13          1 .e-13

START-----1-----*-----2-----*-----3-----*-----4-----*-----5--
---*-----1 MOP: 123456789*123456789*1234 ---*-----5--
PARAM-----1-----*-----2-----*-----3-----*-----4-----*-----5--
  1 100          100100          000000002 30 0 3
          1 .E 5          1 .E 9          -1 .
          1 .E-5          1 .E 00          0 .10
          60 .E 5
RPCAP-----1-----*-----2-----*-----3-----*-----4-----*-----5--
  3          .30          .05
  1          1 .
FOFT-----1-----*-----2-----*-----3-----*-----4-----*-----5--
A1  1

GOFT-----1-----*-----2-----*-----3-----*-----4-----*-----5--

INCON-----1-----*-----2-----*-----3-----*-----4-----*-----5--

GENER-----1-----*-----2-----*-----3-----*-----4-----*-----5--
A1  1wel 1          f725d          4 .64e-11

ENDCY-----1-----*-----2-----*-----3-----*-----4-----*-----5--
GENER-----1-----*-----2-----*-----3-----*-----4-----*-----5--
A1  1wel 1          DELV          4 .64e-11 .

CONNE
A1  1A1  2          1 .5000E+00 .5000E+01 .

```

Figure 13. Input for coupled reservoir-wellbore flow problem.

Table 4. Flowing bottomhole pressures (in Pa) at 1000 m feed zone depth for a well of 20 cm (\approx 8 inch) inside diameter producing at 7 bar wellhead pressure (calculated from HOLA; Aunzo et al., 1991).

```

*f725d* - (q,h) from ( .5000E+00, .1000E+07) to ( .9050E+02, .1400E+07)
  11      9
.5000E+00 .1050E+02 .2050E+02 .3050E+02 .4050E+02 .5050E+02 .6050E+02 .7050E+02
.8050E+02 .9050E+02      1.e3
.1000E+07 .1050E+07 .1100E+07 .1150E+07 .1200E+07 .1250E+07 .1300E+07 .1350E+07
.1400E+07
.1351E+07 .1238E+07 .1162E+07 .1106E+07 .1063E+07 .1028E+07 .9987E+06 .9740E+06
.9527E+06
.1482E+07 .1377E+07 .1327E+07 .1299E+07 .1284E+07 .1279E+07 .1279E+07 .1286E+07
.1292E+07
.2454E+07 .1826E+07 .1798E+07 .1807E+07 .1835E+07 .1871E+07 .1911E+07 .1954E+07
.1998E+07
.4330E+07 .3199E+07 .2677E+07 .2280E+07 .2322E+07 .2376E+07 .2434E+07 .2497E+07
.2559E+07
.5680E+07 .4772E+07 .3936E+07 .3452E+07 .2995E+07 .2808E+07 .2884E+07 .2967E+07
.3049E+07
.6658E+07 .5909E+07 .5206E+07 .4557E+07 .4158E+07 .3746E+07 .3391E+07 .3402E+07
.3511E+07
.7331E+07 .6850E+07 .6171E+07 .5627E+07 .5199E+07 .4814E+07 .4465E+07 .4208E+07
.3957E+07
.7986E+07 .7548E+07 .7140E+07 .6616E+07 .6256E+07 .5908E+07 .5634E+07 .5399E+07
.5128E+07
.8621E+07 .8177E+07 .7820E+07 .7560E+07 .7234E+07 .6814E+07 .6624E+07 .6385E+07
.6254E+07
.8998E+07 .8732E+07 .8453E+07 .8124E+07 .7925E+07 .7671E+07 .7529E+07 .7397E+07
.7269E+07
.5555e+08 .5555e+08 .5555e+08 .5555e+08 .5555e+08 .5555e+08 .5555e+08 .5555e+08
.5555e+08

```

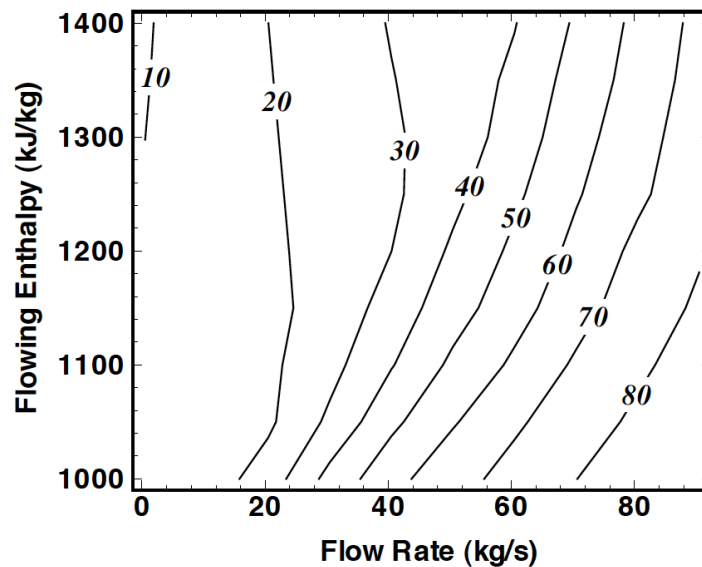

Figure 14. Contour plot of flowing bottomhole pressures, in bars (from Table 4).

References

- Aunzo, Z.P., G. Bjornsson and G.S. Bodvarsson. Wellbore Models GWELL, GWNACL, and HOLA, Lawrence Berkeley National Laboratory Report LBL-31428, Berkeley, CA, October 1991.
- Hadgu, T., R.W. Zimmerman and G.S. Bodvarsson. Coupled Reservoir-Wellbore Simulation of Geothermal Reservoir Behavior. *Geothermics*, Vol. 24, No. 2, pp. 145-166, 1995.
- International Formulation Committee. *A Formulation of the Thermodynamic Properties of Ordinary Water Substance*, IFC Secretariat, Düsseldorf, Germany, 1967.
- Pruess, K. Grid Orientation and Capillary Pressure Effects in the Simulation of Water Injection into Depleted Vapor Zones, *Geothermics*, Vol. 20, No. 5/6, pp. 257 - 277, 1991.
- Pruess, K. and G.S. Bodvarsson. Thermal Effects of Reinjection in Geothermal Reservoirs with Major Vertical Fractures, *J. Pet. Tech.*, Vol. 36, No. 10, pp. 1567 – 1578, 1984.
- Pruess, K. and T.N. Narasimhan. A Practical Method for Modeling Fluid and Heat Flow in Fractured Porous Media, *Soc. Pet. Eng. J.*, Vol. 25, No. 1, pp. 14 - 26, February 1985.

EOS2: An Equation-of-State Module for Water, CO₂

Yoojin Jung
George Pau
Stefan Finsterle

Earth Sciences Division, Lawrence Berkeley National Laboratory
University of California, Berkeley, California 94720

1. Description

This is an updated version of the fluid property module originally developed by O'Sullivan et al. (1985) for describing fluids in gas-rich geothermal reservoirs, which may contain CO₂ mass fractions ranging from a few percent to occasionally 80% or more (Atkinson et al., 1980). EOS2 accounts for non-ideal behavior of gaseous CO₂, and dissolution of CO₂ in the aqueous phase with heat of solution effects. According to Henry's law, the partial pressure of a non-condensable gas (NCG) in the gas phase is proportional to the mole fraction x_{aq}^{NCG} of dissolved NCG in the aqueous phase,

$$P_{NCG} = K_h x_{aq}^{NCG} \quad (1)$$

The Henry's law coefficient K_h for dissolution of CO₂ in water is strongly dependent on temperature. The correlation used in the previous release of EOS2 had been developed by O'Sullivan et al. (1985) for the elevated temperature conditions encountered in geothermal reservoirs. It is accurate to within a few percent of experimental data in the temperature range of $40 \text{ }^\circ\text{C} \leq T \leq 330 \text{ }^\circ\text{C}$, but becomes rather inaccurate at lower temperatures and even goes to negative values for $T < 30 \text{ }^\circ\text{C}$ (see Figure 1). Subroutine HENRY in EOS2 was replaced with a new routine that uses the correlation developed by Battistelli et al. (1997), which is accurate for $0 \text{ }^\circ\text{C} \leq T \leq 350 \text{ }^\circ\text{C}$. The Battistelli et al. formulation agrees well with another correlation that was developed by S. White (1996, private communication).

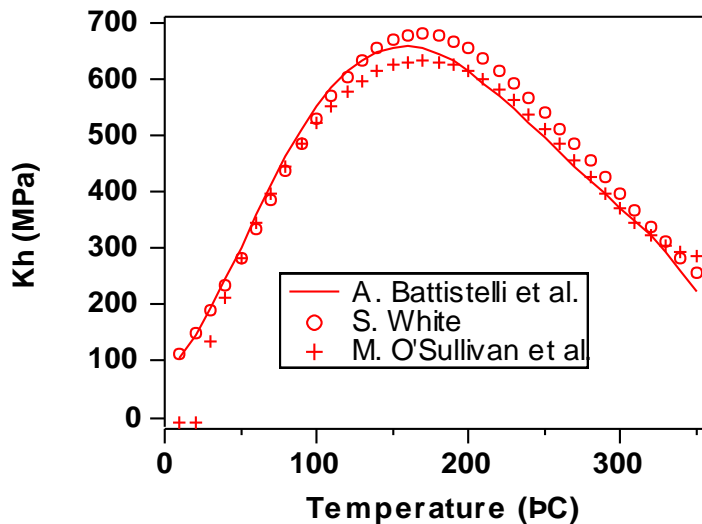

Figure 1. Henry's law coefficients for dissolution of CO₂ in water.

The viscosity of vapor - CO₂ mixtures is described with a formulation due to Pritchett et al. (1981); other thermophysical property correlations are based on the model of Sutton and McNabb (1977).

2. Specifications

A summary of EOS2 specifications and parameters is given in Table 1. A more detailed description and application to geothermal reservoir problems are given in the paper by O'Sullivan et al. (1985). EOS2 has the parameter settings of $(NK, NEQ, NPH, NB) = (2, 3, 2, 6)$ for solving mass and energy balances for water and CO₂. Molecular diffusion can also be modeled by setting parameter NB equal to 8.

Table 5. Summary of EOS2

<u>Components</u>	# 1: water # 2: CO ₂
<u>Parameter choices</u>	$(NK, NEQ, NPH, NB) = (2, 3, 2, 6)$ molecular diffusion can be modeled by setting $NB = 8$
<u>Primary Variables</u>	single-phase conditions (P, T, PCO_2) - (pressure, temperature, CO ₂ partial pressure) two-phase conditions (P_g, S_g, PCO_2) - (gas phase pressure, gas saturation, CO ₂ partial pressure)

3. Sample Problem (*rfp*) - Five-spot Geothermal Production/Injection

This problem is originally developed for EOS1, and here is run with the EOS2 module. For user's convenience, we include much of the details described in the EOS1 addendum.

In geothermal reservoir development, production and injection wells are often sited in more or less regular geometric patterns. The present problem considers a large well field with wells arranged in a "five-spot" configuration (see Figure 2). Because of symmetry only 1/8 of the basic pattern needs to be modeled. The computational grid was generated by means of a separate preprocessor program which has not yet been integrated into the TOUGH3 package. The grid has six rows, each containing between one and eleven elements, for a total of thirty-six volume elements; for simplicity, only a single layer of 305 m thickness is modeled. The problem specifications as given in Table 2 correspond to conditions that may typically be encountered in deeper zones of hot and fairly tight fractured two-phase reservoirs (Pruess and Narasimhan, 1985).

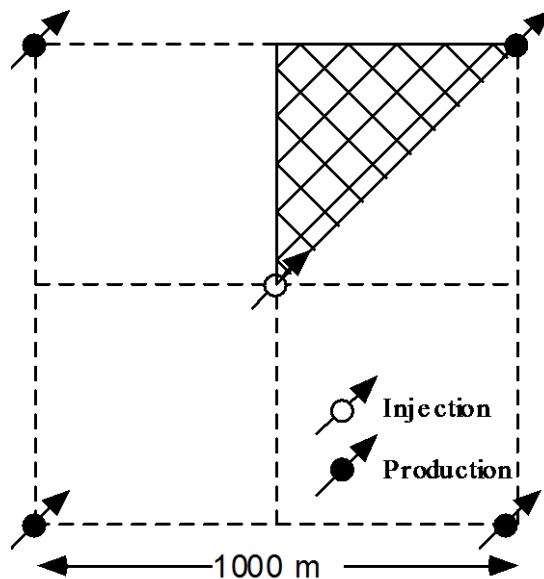

Figure 2. Five-spot well pattern with grid for modeling a 1/8 symmetry domain.

The input file in Figure 3 models the system as a fractured medium with embedded impermeable matrix blocks in the shape of cubes. The matrix blocks were assigned a non-vanishing porosity of 10^{-10} , so that they will contain a small amount of water. This has no noticeable impact on fluid and heat flows, and is done to prevent the water mass balance

equation from degenerating into the singular form $0 = 0$. Running the problem with $\phi = 0$ in the matrix blocks (domain `MATRIX`) is also possible, but this results in more sluggish convergence and considerably smaller time steps. The `MESHMAKER` module is used to perform MINC-partitioning of the primary grid (partition type `THRED` with three equal fracture spacings). The first MINC continuum, corresponding to the fracture domain, occupies a volume fraction of 0.02 and has an intrinsic porosity of 50 %, for an effective fracture porosity of 1 %. By inserting an `ENDCY` record in front of the `MESHM` data block, the MINC process can be disabled and the problem can be run as an effective porous medium. A CO_2 partial pressure of 5 bars is specified. To select variables to print out, data block `OUTPU` is used as shown in Figure 4. Figure 5 shows part of the printout of the flow simulation run.

Table2. Parameters for five-spot problem

Formation	
Rock grain density	2650 kg/m ³
Specific heat	1000 J/kg °C
Heat conductivity	2.1 W/m °C
Permeable volume fraction	2%
Porosity in permeable domain	50%
Impermeable blocks: cubes with side length	50m, 250 m
Permeability	6.0x10 ⁻¹⁵ m ²
Thickness	305 m
Relative permeability: Corey curves	
irreducible liquid saturation	0.30
irreducible gas saturation	0.05
Initial Conditions	
Temperature	300 °C
Liquid saturation	0.99
Pressure	85.93 bar
Production/Injection	
Pattern area	1 km ²
Distance between producers and injectors	707.1 m
Production rate*	30 kg/s
Injection rate*	30 kg/s
Injection enthalpy	500 kJ/kg

* Full well basis

```

* r f p * - 3 6 B L O C K S P A R A L L E L F I V E - S P O T G R I D ( C F . S
ROCKS - - - - 1 - - - - * - - - - 2 - - - - * - - - - 3 - - - - * - - - - 4 - - - - * - - - -
POMED 2 6 5 0 . . 0 1 6 . E - 1 5 6 . E -
FRACT 2 6 5 0 . . 5 0 6 . E - 1 5 6 . E -
MATRX 2 6 5 0 . 1 . E - 1 0 0 . E - 1 5 0 . E -

S T A R T - - - - 1 - - - - * - - - - 2 - - - - * - - - - 3 - - - - * - - - - 4 - - - - * - - - -
- - - - * - - - - 1 M O P : 1 2 3 4 5 6 7 8 9 * 1 2 3 4 5 6 7 8 9 * 1 2 3 4 - - - - * - - - -
P A R A M - - - - 1 - - - - * - - - - 2 - - - - * - - - - 3 - - - - * - - - - 4 - - - - * - - - -
1 9 9 9 9 0 0 0 0 0 0 0 0 0 0 0 0 0 0 0 0 0 4 0
1 . 1 5 1 8 5 2 E 9 - 1 . 3 . 1 5 5 7 6 E 7 K A 1
1 . E 5
1 . E - 5
3 0 0 . 0 . 0 1
R P C A P - - - - 1 - - - - * - - - - 2 - - - - * - - - - 3 - - - - * - - - - 4 - - - - * - - - -
3 . 3 0 . 0 5
1 1 .
T I M E S - - - - 1 - - - - * - - - - 2 - - - - * - - - - 3 - - - - * - - - - 4 - - - - * - - - -
2 2
1 . 5 7 7 8 8 E 8 7 . 8 8 9 4 0 E 8
G E N E R - - - - 1 - - - - * - - - - 2 - - - - * - - - - 3 - - - - * - - - - 4 - - - - * - - - -
A A 1 I N J 1 M A S S 3 .
K A 1 P R O 1 M A S S - 3 .

E L E M E - - - - 1 - - - - * - - - - 2 - - - - * - - - - 3 - - - - * - - - - 4 - - - - * - - - -
A A 1 P O M E D 0 . 1 9 0 6 E + 0 6 0 . 1 2 5 0 E + 0 4
B A 1 P O M E D 0 . 7 6 2 5 E + 0 6 0 . 5 0 0 0 E + 0 4
C A 1 P O M E D 0 . 7 6 2 5 E + 0 6 0 . 5 0 0 0 E + 0 4
D A 1 P O M E D 0 . 7 6 2 5 E + 0 6 0 . 5 0 0 0 E + 0 4
E A 1 P O M E D 0 . 7 6 2 5 E + 0 6 0 . 5 0 0 0 E + 0 4
F A 1 P O M E D 0 . 7 6 2 5 E + 0 6 0 . 5 0 0 0 E + 0 4
G A 1 P O M E D 0 . 7 6 2 5 E + 0 6 0 . 5 0 0 0 E + 0 4
H A 1 P O M E D 0 . 7 6 2 5 E + 0 6 0 . 5 0 0 0 E + 0 4
I A 1 P O M E D 0 . 7 6 2 5 E + 0 6 0 . 5 0 0 0 E + 0 4
J A 1 P O M E D 0 . 7 6 2 5 E + 0 6 0 . 5 0 0 0 E + 0 4
K A 1 P O M E D 0 . 1 9 0 6 E + 0 6 0 . 1 2 5 0 E + 0 4
B B 1 P O M E D 0 . 7 6 2 5 E + 0 6 0 . 5 0 0 0 E + 0 4
C B 1 P O M E D 0 . 1 5 2 5 E + 0 7 0 . 1 0 0 0 E + 0 5
. . .
. . .
G E 1 P O M E D 0 . 7 6 2 5 E + 0 6 0 . 5 0 0 0 E + 0 4
F F 1 P O M E D 0 . 3 8 1 2 E + 0 6 0 . 2 5 0 0 E + 0 4
H T X 0 0 P O M E D 0 .
C O N N E - - - - 1 - - - - * - - - - 2 - - - - * - - - - 3 - - - - * - - - - 4 - - - - * - - - -
A A 1 B A 1 1 0 . 3 5 3 6 E + 0 2 0 . 3 5 3 6 E +
B A 1 C A 1 1 0 . 3 5 3 6 E + 0 2 0 . 3 5 3 6 E +
B A 1 B B 1 2 0 . 3 5 3 6 E + 0 2 0 . 3 5 3 6 E +
C A 1 D A 1 1 0 . 3 5 3 6 E + 0 2 0 . 3 5 3 6 E +
. . .
. . .
F E 1 G E 1 1 0 . 3 5 3 6 E + 0 2 0 . 3 5 3 6 E +
F E 1 F F 1 2 0 . 3 5 3 6 E + 0 2 0 . 3 5 3 6 E +
I N C O N - - - - 1 - - - - * - - - - 2 - - - - * - - - - 3 - - - - * - - - - 4 - - - - * - - - -
M E S H M A K E R 1 - - - - * - - - - 2 - - - - * - - - - 3 - - - - * - - - - 4 - - - - * - - - -
M I N C
P A R T T H R E D D F L T
5 4 O U T 5 0 .
. 0 2 . 0 8 . 2 0 . 3 5
E N D C Y - - - - 1 - - - - * - - - - 2 - - - - * - - - - 3 - - - - * - - - - 4 - - - - * - - - -

```

Figure 3. Input file for five-spot geothermal production/injection.

References

- Atkinson, P.G., R. Celati, R. Corsi and F. Kucuk. Behavior of the Bagnore Steam/ CO₂ Geothermal Reservoir, Italy, *Soc. Pet. Eng. J.*, 228 - 238, 1980.
- Battistelli, A., C. Calore and K. Pruess. The Simulator TOUGH2/EWASG for Modeling Geothermal Reservoirs with Brines and Non-Condensable Gas, *Geothermics*, Vol. 26, No. 4, pp. 437 - 464, 1997.
- O'Sullivan, M.J., G.S. Bodvarsson, K. Pruess and M.R. Blakeley. Fluid and Heat Flow in Gas-Rich Geothermal Reservoirs, *Society of Petroleum Engineers Journal*, Vol. 25, No. 2, pp. 215 - 226, April 1985.
- Pritchett, J.W., M.H. Rice and T.D. Riney. Equation-of-State for Water-Carbon Dioxide Mixtures: Implications for Baca Reservoir, Report DOE/ET/27163-8, Systems, Science and Software, La Jolla, CA, February 1981.
- Pruess, K. and T.N. Narasimhan. A Practical Method for Modeling Fluid and Heat Flow in Fractured Porous Media, *Soc. Pet. Eng. J.*, Vol. 25, No. 1, pp. 14 - 26, February 1985.
- Sutton, F.M. and A. McNabb. Boiling Curves at Broadlands Field, New Zealand, *N. Z. J. Sci.*, Vol. 20, pp. 333 - 337, 1977.

EOS3: An Equation-of-State Module for Water, Air

Yoojin Jung
George Pau
Stefan Finsterle

Earth Sciences Division, Lawrence Berkeley National Laboratory
University of California, Berkeley, California 94720

1. Description

This module is an adaptation of the EOS module of the TOUGH simulator, and implements the same thermophysical properties model (Pruess, 1987). All water properties are represented by the steam table equations as given by the International Formulation Committee (1967). Air is approximated as an ideal gas, and additivity is assumed for air and vapor partial pressures in the gas phase, $P_g = P_a + P_v$. The viscosity of air-vapor mixtures is computed from a formulation given by Hirschfelder et al. (1954). The solubility of air in liquid water is represented by Henry's law, as follows.

$$P_a = K_h x_{aq}^a \quad (1)$$

where K_h is Henry's constant and x_{aq}^a is air mole fraction in the aqueous phase. Henry's constant for air dissolution in water is a slowly varying function of temperature, varying from 6.7×10^9 Pa at 20 °C to 1.0×10^{10} Pa at 60 °C and 1.1×10^{10} Pa at 100 °C (Loomis, 1928). Because air solubility is small, this kind of variation is not expected to cause significant effects, and a constant $K_h = 10^{10}$ Pa was adopted.

2. Specifications

A summary of EOS3 specifications and parameters is given in Table 1. The default parameter settings are $(NK, NEQ, NPH, NB) = (2, 3, 2, 6)$. The option $NEQ = 2$ is available for constant temperature conditions. The choice of primary thermodynamic variables is (P, X, T) for single-phase, $(P_g, S_g + 10, T)$ for two-phase conditions. The rationale for the seemingly bizarre choice of $S_g + 10$ as a primary variable is as follows. As an option, we wish to be able to run isothermal two-phase flow problems with the specification $NEQ = NK$, so that the then superfluous heat balance equation needs not be engaged. This requires that temperature T be the third primary variable. The logical choice of primary variables would then appear to be (P, X, T) for single-phase and (P_g, S_g, T) for two-phase conditions. However, both X and S_g vary over the range $(0, 1)$, so that this would not allow a distinction of single-phase from two-phase conditions solely from the numerical range of primary variables. By taking the second primary variable for two-phase conditions to be $X2 = 10 + S_g$, the range of that variable is shifted to the interval $(10, 11)$, and a distinction between single and two-phase conditions can be easily made. As a convenience to users, we retain the capability to optionally initialize flow problems with

TOUGH-style primary variables by setting $MOP(19) = 1$. In TOUGH we have (P, T, X) for single-phase conditions, (P_g, S_g, T) for two-phase conditions.

Table 6. Summary of EOS3

<u>Components</u>	# 1: water # 2: air
<u>Parameter choices</u>	
$(NK, NEQ, NPH, NB) =$	(2, 3, 2, 6) water and air, nonisothermal (default) (2, 2, 2, 6) water and air, isothermal molecular diffusion can be modeled by setting $NB = 8$
<u>Primary Variables</u> *	
single-phase conditions	(P, X, T) - (pressure, air mass fraction, temperature)
two-phase conditions	$(P_g, S_g + 10, T)$ - (gas phase pressure, gas saturation plus 10, temperature)

* By setting $MOP(19) = 1$, initialization can be made with TOUGH-style variables (P, T, X) for single-phase, (P_g, S_g, T) for two-phase.

3. Sample Problems

3.1. Problem No. 1 (*eos3p1*) - Code Demonstration

This problem demonstrates various initialization options and generation specifications. A number of one- and two-element subproblems are simulated which are entirely independent of each other (no flow connections between subproblems), except that being run together they all must go through the same sequence of time steps. The sub-problems perform flow and/or injection and withdrawal of water, air, and heat, with highly nonlinear phase and component (dis-)appearances that engage some subtle numerical procedures. The input file for running with the EOS3 fluid properties module is given in Figure 1. Parameter *MOP* (19) in the first record of data block **PARAM** was set equal to 1, to permit initialization of the EOS3 module with TOUGH-style primary variables of (P, T, X) for single phase, (P, S, T) for two-phase. Data block **OUTPU** is used to select variables to print out, and data blocks **FOFT** and **GOFT** are used to generate time series for selected grid blocks and generation items that can be used for plotting. Figures 2 and 3 show the disk files **MESH** and **SAVE** generated by the TOUGH3 run, and Figure 4 gives the printed output in the CSV format.

```

*eos3p1* CODE DEMONSTRATION: PHASE TRANSITIONS, COMPONENT (DIS-)APPEARANCES
ROCKS-----1-----*-----2-----*-----3-----*-----4-----*-----5-----*-----6-----*-----7-----*-----8
TRANS          2650.          .50    1.E-14          2.10    1000.
SHOME    2      2650.          .50    1.E-14          2.10    1000.
          1.8          .1
          3          .40          .10
          1          1.E5          .2          1.

START-----1-----*-----2-----*-----3-----*-----4-----*-----5-----*-----6-----*-----7-----*-----8
-----*-----1 MOP: 123456789*123456789*1234 -----*-----5-----*-----6-----*-----7-----*-----8
PARAM-----1-----*-----2-----*-----3-----*-----4-----*-----5-----*-----6-----*-----7-----*-----8
          2    4      1100 30 000000000711
          -1.
          1.E2      5.E3
          45.E5          .5          250.

FOFT -----1-----*-----2-----*-----3-----*-----4-----*-----5-----*-----6-----*-----7-----*-----8
F    1
F    7

GOFT -----1-----*-----2-----*-----3-----*-----4-----*-----5-----*-----6-----*-----7-----*-----8
SHO 9P  9
F    8WEL 1

RPCAP-----1-----*-----2-----*-----3-----*-----4-----*-----5-----*-----6-----*-----7-----*-----8
          3          .30          .05
          1          1.

TIMES-----1-----*-----2-----*-----3-----*-----4-----*-----5-----*-----6-----*-----7-----*-----8
          1    3          2.E3
          1.E3

ELEME-----1-----*-----2-----*-----3-----*-----4-----*-----5-----*-----6-----*-----7-----*-----8
F    1    9    1TRANS    10.
SHO 1    9    1SHOME    10.
SHO11   1    1SHOME    1.E4

CONNE-----1-----*-----2-----*-----3-----*-----4-----*-----5-----*-----6-----*-----7-----*-----8
F    1F  2          1    5.    5.    1.
F    3F  4          1    5.    5.    1.
F    5F  6          1    5.    5.    1.

GENER-----1-----*-----2-----*-----3-----*-----4-----*-----5-----*-----6-----*-----7-----*-----8
F    7AIR 1          AIR    5.E-3    9.882E4
F    8WEL 1          MASS   -1.5E-2
F    9HOT 1          HEAT    2.E6
F   10COL 1          HEAT   -5.E5
SHO 1P  1          MASS1   -1.    1.E6
SHO 3P  3    2    1    1    4    MASS
          0.    1.E2    2.E2    4.E3
          -0.1  -0.2    -0.3    -1.1
SHO 6P  6    2    1    0    4    MASS1
          0.    1.E2    2.E2    4.E3
          -0.1  -0.2    -0.3    -1.1
          1.E6    2.E6    3.E6    1.1E7
SHO 9P  9          1    DELV    1.E-12    1.E6
SHO10P 10         4    WATE1
          0.    1.E2    2.E2    3.E3
          1.1    1.0    0.9    0.1
          1.E6    1.2E6    1.4E6    3.0E6
SHO11WEL00        2    DELV    1.E-12    1.E2
SHO12WEL00        DELV    2.E-12    1.E6    1.E2

```

Figure 15. Input file for problem eos3p1.

```

INCON----1----*----2----*----3----*----4----*----5----*----6----*----7----*----8
F  1          1.E5          20.          1.
F  2          1.E6          170.         0.
F  3          1.E5          .001         99.5
F  4          99.E5         .999         310.
F  5          1.E6          100.         0.
F  6          10.E6         100.         1.
F  7          1.E5          20.          0.
F  8          1.E7          300.         0.
F  9          1.E5          .99          90.
F 10          40.E5         280.         0.
SHO11         50.E5         240.
SHO12         40.E5         100.

OUTPU----1----*----2----*----3----*----4----*----5----*----6----*----7----*----8
  4
PRESSURE
TEMPERATURE
SATURATION      2
MASS FRACTION   1  1

ENDCY----1----*----2----*----3----*----4----*----5----*----6----*----7----*----8

```

Figure 16. Input file for problem eos3p1 (continued).

```

ELEME5  NX=  0  NY=  0  NZ=  0
F0001      1      10.
F0002      1      10.
F0003      1      10.
F0004      1      10.
F0005      1      10.
F0006      1      10.
F0007      1      10.
F0008      1      10.
F0009      1      10.
F0010      1      10.
SHO01      2      10.
SHO02      2      10.
SHO03      2      10.
SHO04      2      10.
SHO05      2      10.
SHO06      2      10.
SHO07      2      10.
SHO08      2      10.
SHO09      2      10.
SHO10      2      10.
SHO11      2      1.E4
SHO12      2      1.E4

CONNE
F0001F0002      1      5.      5.      1.
F0003F0004      1      5.      5.      1.
F0005F0006      1      5.      5.      1.

```

Figure 2. File MESH for sample problem 1.

```

INCON
F0001      0.50000000E+00
  0.1026051544293E+06 0.1099873452467E+02 0.2029461487225E+02
F0002      0.50000000E+00
  0.7916538302560E+06 0.1000130477465E+02 0.1699807306491E+03
F0003      0.50000000E+00
  0.7087717395214E+07 0.1109346358337E-04 0.1009252092109E+03
F0004      0.50000000E+00
  0.9595741498288E+07 0.3232199089739E-02 0.3092321634781E+03
F0005      0.50000000E+00
  0.9466340712745E+07 0.1000245529012E+02 0.1003008252748E+03
F0006      0.50000000E+00
  0.9820587229007E+07 0.1000000000000E+01 0.9993464211560E+02
F0007      0.50000000E+00
  0.8223901978255E+07 0.1000232048300E+02 0.2007769343077E+02
F0008      0.50000000E+00
  0.8540126267896E+07 0.1000356017236E+02 0.2995646332663E+03
F0009      0.50000000E+00
  0.2615774041817E+07 0.2741571459753E-01 0.3146697034761E+03
F0010      0.50000000E+00
  0.2569400159523E+07 0.1099368941537E+02 0.2254031968151E+03
SHO01      0.50000000E+00
  0.4523833521424E+07 0.1089755837829E+02 0.2536085826695E+03
SHO02      0.50000000E+00
  0.4500000000000E+07 0.1050000000000E+02 0.2500000000000E+03
SHO03      0.50000000E+00
  0.1563318283525E+07 0.1066957995322E+02 0.2002223364136E+03
SHO04      0.50000000E+00
  0.1563318283525E+07 0.1066957995322E+02 0.2002223364136E+03
SHO05      0.50000000E+00
  0.1563318283525E+07 0.1066957995322E+02 0.2002223364136E+03
SHO06      0.50000000E+00
  0.8910684547344E+06 0.1068461230930E+02 0.1571058124105E+03
SHO07      0.50000000E+00
  0.8910684547344E+06 0.1068461230930E+02 0.1571058124105E+03
SHO08      0.50000000E+00
  0.8910684547344E+06 0.1068461230930E+02 0.1571058124105E+03
SHO09      0.50000000E+00
  0.1393798601320E+07 0.1068442642212E+02 0.1948134940678E+03
SHO10      0.50000000E+00
  0.7416199627942E+07 0.1016006223789E+02 0.2737594793659E+03
SHO11      0.50000000E+00
  0.3333351946055E+07 0.1000259651765E+02 0.2397536594926E+03
SHO12      0.50000000E+00
  0.1199540904818E+07 0.0000000000000E+00 0.9988300477347E+02
+++
  4 21 2 0.00000000E+00 0.15470647E+04
INCON -- INITIAL CONDITIONS FOR 22 ELEMENTS AT TIME 0.154706E+04

```

Figure 3. File SAVE for sample problem 1.

"	ELEM", "	PRES", "	TEMP", "	SAT_L", "	X_WATER_G"
"	"", "	(PA)", "	(DEC-C)", "	(-)", "	(-)"
"TIME [sec]	0.10000000E+03				
"	F0001",	0.102346703657E+06,	0.200063555872E+02,	0.715014321280E-04,	0.143472935544E-01
"	F0002",	0.844100286987E+06,	0.169987848962E+03,	0.100000000000E+01,	0.000000000000E+00
"	F0003",	0.105700866172E+06,	0.995912521633E+02,	0.999340701542E+00,	0.915216435648E+00
"	F0004",	0.988605610524E+07,	0.309897535052E+03,	0.733792521704E-03,	0.996737825741E+00
"	F0005",	0.264549197917E+07,	0.100054890205E+03,	0.999625640886E+00,	0.246013794144E-01
"	F0006",	0.995662087272E+07,	0.999841984044E+02,	0.000000000000E+00,	0.000000000000E+00
"	F0007",	0.619227445441E+06,	0.200048350968E+02,	0.999863888468E+00,	0.235403966431E-02
"	F0008",	0.981102346685E+07,	0.299948537443E+03,	0.100000000000E+01,	0.000000000000E+00
"	F0009",	0.150451644607E+06,	0.104653956003E+03,	0.982540929834E-02,	0.708509306821E+00
"	F0010",	0.395969725849E+07,	0.276279402173E+03,	0.000000000000E+00,	0.100000000000E+01
"	SH001",	0.448733972406E+07,	0.250172823380E+03,	0.474480822893E+00,	0.858082460362E+00
"	SH002",	0.450000000000E+07,	0.250000000000E+03,	0.500000000000E+00,	0.851765457446E+00
"	SH003",	0.432388601714E+07,	0.249023146174E+03,	0.495993610891E+00,	0.877422415406E+00
"	SH004",	0.432388601714E+07,	0.249023146174E+03,	0.495993610891E+00,	0.877422415406E+00
"	SH005",	0.432388601714E+07,	0.249023146174E+03,	0.495993610891E+00,	0.877422415406E+00
"	SH006",	0.447635018546E+07,	0.249711890057E+03,	0.495949593902E+00,	0.852113123660E+00
"	SH007",	0.447635018546E+07,	0.249711890057E+03,	0.495949593902E+00,	0.852113123660E+00
"	SH008",	0.447635018546E+07,	0.249711890057E+03,	0.495949593902E+00,	0.852113123660E+00
"	SH009",	0.327913088760E+07,	0.237127028644E+03,	0.449324952255E+00,	0.960001700093E+00
"	SH010",	0.454621341425E+07,	0.250255400511E+03,	0.527112646674E+00,	0.845452628615E+00
"	SH011",	0.454287793513E+07,	0.239935889131E+03,	0.100000000000E+01,	0.000000000000E+00
"	SH012",	0.329570308042E+07,	0.999706282529E+02,	0.100000000000E+01,	0.000000000000E+00
"TIME [sec]	0.10000000E+04				
"	F0001",	0.102507380925E+06,	0.201857776217E+02,	0.814121653226E-03,	0.144860853046E-01
"	F0002",	0.791676326723E+06,	0.169981905996E+03,	0.999201095480E+00,	0.100000000000E+01
"	F0003",	0.489050357849E+07,	0.100562472271E+03,	0.100000000000E+01,	0.000000000000E+00
"	F0004",	0.968333825464E+07,	0.309361785444E+03,	0.000000000000E+00,	0.996767800910E+00
.....					
.....					

Figure 4. Printed output variables in CSV format based on **OUTPUT** block shown in Figure 1.

3.2.Problem No. 2 (*rhp*) - Heat Pipe in Cylindrical Geometry

Heat pipes are systems in which an efficient heat transfer takes place by means of a liquid-vapor counterflow process, with vaporization and condensation occurring at the hot and cold ends, respectively. Heat pipe processes occur naturally on a large scale (kilometers) in two-phase geothermal reservoirs, and they may be induced artificially if heat-generating nuclear waste packages are emplaced above the water table in partially saturated geologic formations.

The present problem models such high-level nuclear waste emplacement in an approximate way. The input file shown in Figure 5 specifies a cylindrical heater of 0.3 m radius and 4.5 m height, that provides a constant output of 3 kW into a porous medium with uniform initial conditions of 18 °C temperature, 1 bar pressure, and 20 % gas saturation. The MESHMAKER module is used to generate a one-dimensional radial grid of 120 active elements extending to a radius of 10,000 m (practically infinite for the time scales of interest here), with an additional element of a very large volume representing constant boundary conditions. Properly speaking, the problem represents one unit of an infinite linear string of identical heaters; if a single heater were to be modeled, important end effects would occur at the top and bottom, and a two-dimensional *R-Z* grid would have to be used.

```

*rbp* 1-D RADIAL HEAT PIPE
MESHMAKER1-----2-----3-----4-----5-----6-----7-----8
RZ2D
RADII
  1
    0.
EQUID
  1          .3
LOGAR
  99          1.E2
LOGAR
  20          1.E4
LAYER-----1-----2-----3-----4-----5-----6-----7-----8
  1
    4.5
ROCKS-----1-----2-----3-----4-----5-----6-----7-----8
POMED  1      2550.      .10  20.E-15  20.E-15  20.E-15      2.0  800.0
      .25
MULTI-----1-----2-----3-----4-----5-----6-----7-----8
  2  3  2  6
START-----1-----2-----3-----4-----5-----6-----7-----8
----*-----1 MOP: 123456789*123456789*1234 ----*-----5-----6-----7-----8
PARAM-----1-----2-----3-----4-----5-----6-----7-----8
  2 250      25010003000000000 47 1      1.80
      3.15576E8      -1.
      1.E3      9.E3      9.E4      4.E5
      1.E-5      1.E00      1.E-7
      1.E5      0.20      18.
SOLVR-----1-----2-----3-----4-----5-----6-----7-----8
5 Z0 00 8.0e-1 1.0e-7
diffusivity data are input as follows:
first row water, second row air; first column gas, second column aqueous
DIFFU-----1-----2-----3-----4-----5-----6-----7-----8
  2.13e-5      0.e-8
  2.13e-5      0.e-8
RPCAP-----1-----2-----3-----4-----5-----6-----7-----8
  7      0.45000  9.6E-4  1.
  7      0.45000  1.0E-3  8.0E-05  5.E8  1.
TIMES-----1-----2-----3-----4-----5-----6-----7-----8
  3
  3.15576E7  1.2559E8  3.15576E8
INCON-----1-----2-----3-----4-----5-----6-----7-----8
GENER-----1-----2-----3-----4-----5-----6-----7-----8
A1 1HTR 1      HEAT      3.E3
OUTPU-----1-----2-----3-----4-----5-----6-----7-----8
  4
PRESSURE
TEMPERATURE
SATURATION      2
MASS FRACTION      1  2
ENDCY-----1-----2-----3-----4-----5-----6-----7-----8

```

Figure 5. Input file for problem 2 – heat pipe in cylindrical geometry.

Most of the formation parameters are identical to data used in previous modeling studies of high-level nuclear waste emplacement at Yucca Mountain (Pruess et al., 1990). As we do not include fracture effects in the present simulation, heat pipe effects would be very weak at the low rock matrix permeabilities (of order 1 microdarcy) encountered at Yucca Mountain. To get a more interesting behavior, we have arbitrarily increased absolute permeability by something like a factor 10,000, to 20 millidarcy, and for consistency have reduced capillary pressures by a factor $(10,000)^{1/2} = 100$ in comparison to typical Yucca Mountain data.

To provide a benchmark for proper code installation, we present portions of the printed output. Figure 6 shows part of the iteration sequence and thermodynamic data after $t = 1$ yr for running the input file as given in Figure 5. Note TOUGH3 printed out only the variables selected in data block **OUTPU**. The input file in Figure 5 includes data for vapor-air diffusion, which can be engaged by changing parameter *NB* in data block **MULTI** from 6 to 8. Some of the output when diffusion is included is shown in Figure 7. Comparison with Figure 6 shows that some air remains in the boiling region near the heater when diffusion is active. Vapor is removed from the hot region at somewhat larger rates, causing liquid saturations to be somewhat smaller. This makes the heat pipe less efficient, and leads to slightly higher temperatures.

```

...ITERATING... AT [ 1, 1] --- DELTEX = 0.100000E+04 MAX. RES. = 0.603498E-01 AT ELEMENT A1001 EQUATION 3
A1001( 1, 2) ST = 0.100000E+04 DT = 0.100000E+04
...ITERATING... AT [ 2, 1] --- DELTEX = 0.900000E+04 MAX. RES. = 0.502678E+00 AT ELEMENT A1001 EQUATION 3
...ITERATING... AT [ 2, 2] --- DELTEX = 0.900000E+04 MAX. RES. = 0.311634E-03 AT ELEMENT A1001 EQUATION 1
A1001( 2, 3) ST = 0.100000E+05 DT = 0.900000E+04
...ITERATING... AT [ 3, 1] --- DELTEX = 0.900000E+05 MAX. RES. = 0.300126E+01 AT ELEMENT A1001 EQUATION 3
...ITERATING... AT [ 3, 2] --- DELTEX = 0.900000E+05 MAX. RES. = 0.388987E-02 AT ELEMENT A1001 EQUATION 1
...ITERATING... AT [ 3, 3] --- DELTEX = 0.900000E+05 MAX. RES. = 0.212915E-04 AT ELEMENT A1001 EQUATION 1
A1001( 3, 4) ST = 0.100000E+06 DT = 0.900000E+05
...ITERATING... AT [ 4, 1] --- DELTEX = 0.400000E+06 MAX. RES. = 0.252316E+01 AT ELEMENT A1001 EQUATION 3
...ITERATING... AT [ 4, 2] --- DELTEX = 0.400000E+06 MAX. RES. = 0.211348E+02 AT ELEMENT A1001 EQUATION 1
...ITERATING... AT [ 4, 3] --- DELTEX = 0.400000E+06 MAX. RES. = 0.466754E+01 AT ELEMENT A1001 EQUATION 1
...ITERATING... AT [ 4, 4] --- DELTEX = 0.400000E+06 MAX. RES. = 0.110662E+01 AT ELEMENT A1001 EQUATION 1
...ITERATING... AT [ 4, 5] --- DELTEX = 0.400000E+06 MAX. RES. = 0.178300E+00 AT ELEMENT A1001 EQUATION 1
...ITERATING... AT [ 4, 6] --- DELTEX = 0.400000E+06 MAX. RES. = 0.331180E-03 AT ELEMENT A1001 EQUATION 1
A1001( 4, 7) ST = 0.500000E+06 DT = 0.400000E+06
...ITERATING... AT [ 5, 1] --- DELTEX = 0.400000E+06 MAX. RES. = 0.489501E+00 AT ELEMENT A1002 EQUATION 3
...ITERATING... AT [ 5, 2] --- DELTEX = 0.400000E+06 MAX. RES. = 0.121238E+02 AT ELEMENT A1001 EQUATION 1
...ITERATING... AT [ 5, 3] --- DELTEX = 0.400000E+06 MAX. RES. = 0.303740E+01 AT ELEMENT A1001 EQUATION 1
...ITERATING... AT [ 5, 4] --- DELTEX = 0.400000E+06 MAX. RES. = 0.229988E+00 AT ELEMENT A1001 EQUATION 1
...ITERATING... AT [ 5, 5] --- DELTEX = 0.400000E+06 MAX. RES. = 0.149697E-02 AT ELEMENT A1001 EQUATION 1
A1001( 5, 6) ST = 0.900000E+06 DT = 0.400000E+06
...ITERATING... AT [ 6, 1] --- DELTEX = 0.400000E+06 MAX. RES. = 0.502032E+00 AT ELEMENT A1001 EQUATION 1
...ITERATING... AT [ 6, 2] --- DELTEX = 0.400000E+06 MAX. RES. = 0.218262E+01 AT ELEMENT A1001 EQUATION 1
...ITERATING... AT [ 6, 3] --- DELTEX = 0.400000E+06 MAX. RES. = 0.815737E-01 AT ELEMENT A1001 EQUATION 1
...ITERATING... AT [ 6, 4] --- DELTEX = 0.400000E+06 MAX. RES. = 0.102201E-03 AT ELEMENT A1001 EQUATION 1
A1001( 6, 5) ST = 0.130000E+07 DT = 0.400000E+06
...ITERATING... AT [ 7, 1] --- DELTEX = 0.400000E+06 MAX. RES. = 0.172430E+00 AT ELEMENT A1001 EQUATION 1
...ITERATING... AT [ 7, 2] --- DELTEX = 0.400000E+06 MAX. RES. = 0.916549E+00 AT ELEMENT A1001 EQUATION 1
...ITERATING... AT [ 7, 3] --- DELTEX = 0.400000E+06 MAX. RES. = 0.119902E-01 AT ELEMENT A1001 EQUATION 1
A1001( 7, 4) ST = 0.170000E+07 DT = 0.400000E+06
...ITERATING... AT [ 8, 1] --- DELTEX = 0.800000E+06 MAX. RES. = 0.245243E+00 AT ELEMENT A1005 EQUATION 3
...ITERATING... AT [ 8, 2] --- DELTEX = 0.800000E+06 MAX. RES. = 0.462618E+02 AT ELEMENT A1001 EQUATION 1
...ITERATING... AT [ 8, 3] --- DELTEX = 0.800000E+06 MAX. RES. = 0.698163E+01 AT ELEMENT A1001 EQUATION 1
...ITERATING... AT [ 8, 4] --- DELTEX = 0.800000E+06 MAX. RES. = 0.761630E+00 AT ELEMENT A1001 EQUATION 1
...ITERATING... AT [ 8, 5] --- DELTEX = 0.800000E+06 MAX. RES. = 0.248040E-01 AT ELEMENT A1002 EQUATION 1
...ITERATING... AT [ 8, 6] --- DELTEX = 0.800000E+06 MAX. RES. = 0.118518E-02 AT ELEMENT A1001 EQUATION 1
A1001( 8, 7) ST = 0.250000E+07 DT = 0.800000E+06
...ITERATING... AT [ 9, 1] --- DELTEX = 0.800000E+06 MAX. RES. = 0.167720E+00 AT ELEMENT A1001 EQUATION 1
...ITERATING... AT [ 9, 2] --- DELTEX = 0.800000E+06 MAX. RES. = 0.638455E+01 AT ELEMENT A1001 EQUATION 1
...ITERATING... AT [ 9, 3] --- DELTEX = 0.800000E+06 MAX. RES. = 0.989682E+00 AT ELEMENT A1001 EQUATION 1
...ITERATING... AT [ 9, 4] --- DELTEX = 0.800000E+06 MAX. RES. = 0.812377E-02 AT ELEMENT A1001 EQUATION 1
A1001( 9, 5) ST = 0.330000E+07 DT = 0.800000E+06
...ITERATING... AT [ 10, 1] --- DELTEX = 0.800000E+06 MAX. RES. = 0.308271E+00 AT ELEMENT A1001 EQUATION 1
...ITERATING... AT [ 10, 2] --- DELTEX = 0.800000E+06 MAX. RES. = 0.227640E+01 AT ELEMENT A1001 EQUATION 1
...ITERATING... AT [ 10, 3] --- DELTEX = 0.800000E+06 MAX. RES. = 0.710785E-01 AT ELEMENT A1001 EQUATION 1
...ITERATING... AT [ 10, 4] --- DELTEX = 0.800000E+06 MAX. RES. = 0.537569E-04 AT ELEMENT A1001 EQUATION 1
A1001( 10, 5) ST = 0.410000E+07 DT = 0.800000E+06
...ITERATING... AT [ 11, 1] --- DELTEX = 0.800000E+06 MAX. RES. = 0.288093E+00 AT ELEMENT A1001 EQUATION 1
...ITERATING... AT [ 11, 2] --- DELTEX = 0.800000E+06 MAX. RES. = 0.591824E+00 AT ELEMENT A1002 EQUATION 1
...ITERATING... AT [ 11, 3] --- DELTEX = 0.800000E+06 MAX. RES. = 0.623477E-02 AT ELEMENT A1002 EQUATION 1
.....
.....
A1002( 43, 5) ST = 0.309000E+08 DT = 0.800000E+06
...ITERATING... AT [ 44, 1] --- DELTEX = 0.657600E+06 MAX. RES. = 0.769131E-01 AT ELEMENT A1003 EQUATION 1
...ITERATING... AT [ 44, 2] --- DELTEX = 0.657600E+06 MAX. RES. = 0.111581E+02 AT ELEMENT A1002 EQUATION 1
...ITERATING... AT [ 44, 3] --- DELTEX = 0.657600E+06 MAX. RES. = 0.546051E+00 AT ELEMENT A1002 EQUATION 1
...ITERATING... AT [ 44, 4] --- DELTEX = 0.657600E+06 MAX. RES. = 0.140214E-02 AT ELEMENT A1002 EQUATION 1
A1002( 44, 5) ST = 0.315576E+08 DT = 0.657600E+06
*rhp* 1-D RADIAL HEAT PIPE

OUTPUT DATA AFTER ( 44, 5)-2-TIME STEPS THE TIME IS 0.365250E+03 DAYS
*****
TOTAL TIME KCYC ITER ITCR KON DX1M DX2M DX3M MAX. RES. NER KER DELTEX
0.315576E+08 44 5 236 2 0.42630E+03 0.11943E-01 0.58034E+00 0.10758E-06 2 1 0.65760E+06
*****

ELEM. INDEX PRES TEMP SAT_L X AIR_G
(PA) (DEC-C) (-) (-)

A1001 1 0.14573E+06 0.1641E+03 0.0000E+00 0.0000E+00
A1002 2 0.14573E+06 0.1105E+03 0.2572E-02 0.0000E+00
A1003 3 0.13007E+06 0.1071E+03 0.1315E+00 0.0000E+00
A1004 4 0.11877E+06 0.1045E+03 0.3843E+00 0.0000E+00
A1005 5 0.10974E+06 0.1022E+03 0.5811E+00 0.2634E-10
A1006 6 0.10204E+06 0.1002E+03 0.7706E+00 0.2645E-05
A1007 7 0.10004E+06 0.9293E+02 0.8270E+00 0.3060E+00
A1008 8 0.10004E+06 0.8493E+02 0.8257E+00 0.5392E+00
A1009 9 0.10004E+06 0.7795E+02 0.8246E+00 0.6738E+00
A1010 10 0.10004E+06 0.7179E+02 0.8234E+00 0.7588E+00
A1011 11 0.10004E+06 0.6631E+02 0.8222E+00 0.8159E+00
A1012 12 0.10004E+06 0.6138E+02 0.8211E+00 0.8558E+00
A1013 13 0.10004E+06 0.5694E+02 0.8200E+00 0.8847E+00
A1014 14 0.10004E+06 0.5292E+02 0.8189E+00 0.9061E+00
A1015 15 0.10004E+06 0.4926E+02 0.8178E+00 0.9223E+00
.....
.....

```

Figure 6. Selected output for problem 2 run.

References

- Hirschfelder, J.O., C.F. Curtiss and R.B. Bird. *Molecular Theory of Gases and Liquids*, John Wiley & Sons, New York, NY, 1954.
- International Formulation Committee. *A Formulation of the Thermodynamic Properties of Ordinary Water Substance*, IFC Secretariat, Düsseldorf, Germany, 1967.
- Loomis, A.G. Solubilities of Gases in Water, in: *International Critical Tables, Vol. III*, E. W. Washburn, (ed.), McGraw-Hill, New York, NY, pp. 255–257, 1928.
- Pruess, K. TOUGH User's Guide, Nuclear Regulatory Commission Report NUREG/CR-4645; also Lawrence Berkeley Laboratory Report LBL-20700, 1987.
- Pruess, K., J.S.Y. Wang and Y.W. Tsang. On Thermohydrological Conditions Near High-Level Nuclear Wastes Emplaced in Partially Saturated Fractured Tuff. Part 2. Effective Continuum Approximation, *Water Resour. Res.*, Vol. 26, No. 6, pp. 1249 - 1261, 1990.

EOS4: An Equation-of-State Module for Water, Air, with Vapor Pressure Lowering Capability

Yoojin Jung
George Pau
Stefan Finsterle

Earth Sciences Division, Lawrence Berkeley National Laboratory
University of California, Berkeley, California 94720

1. Description

This module is an adaptation of the EOS3 module, and implements vapor pressure lowering effects. Vapor pressure P_v is expressed by Kelvin's equation, Eq. 1 (Edlefsen and Anderson, 1943); it is a function not only of temperature, but depends also on capillary pressure, which in turn is a function of saturation.

$$P_v(T, S_l) = f_{VPL}(T, S_l) P_{sat}(T) \quad (1)$$

where

$$f_{VPL} = \exp \left[\frac{M_w P_{cl}(S_l)}{\rho_l R (T + 273.15)} \right] \quad (2)$$

is the vapor pressure lowering factor. P_{sat} is the saturated vapor pressure of bulk aqueous phase, T is temperature, S_l is the liquid (water) saturation, P_{cl} is the capillary pressure (i.e., the difference between aqueous and gas phase pressures), M_w is the molecular weight of water, ρ_l is the liquid density, and R is the universal gas constant.

2. Specifications

A summary of EOS4 specifications and parameters is given in Table 1. The default parameter settings are $(NK, NEQ, NPH, NB) = (2, 3, 2, 6)$. The option for single-component mode of water only, no air ($NK = 1$) is available for nonisothermal conditions ($NEQ = 2$). The specification of thermophysical properties in this EOS differs from EOS3 in that provision is made for vapor pressure lowering effects. The primary variables are (P, T, P_a) for single-phase conditions and (P_g, S_g, P_a) for two-phase conditions, where P_a is the partial pressure of air. Note that in two-phase conditions temperature is not among the primary variables. It is implicitly determined from the relationship $P_g - P_a = P_v$, with $P_v = P_v(T, S_l)$ as given in Eq. 1.

It would be possible to use other sets of primary variables; in particular, temperature could be used also in two-phase conditions. Our test calculations for a number of examples indicated, however, that the choice (P_g, S_g, P_a) usually leads to better convergence behavior than the choice (P_g, S_g, T) . The reason for the numerically inferior behavior of the latter set is in the

air mass balance. With the variables (P_g, S_g, T) , the amount of air present in a grid block becomes controlled by the difference between total gas pressure P_g and effective vapor pressure $P_v = P_{sat}(T) \cdot f_{VPL}(T, S_l)$ (Eq. 1), which can be subject to very severe numerical cancellation. From the applications viewpoint, however, initialization of a flow problem with the set (P_g, S_g, T) may be much more physical and convenient. EOS4 allows the initialization of two-phase points as (P_g, S_g, T) ; this capability can be selected by specifying $MOP(19) = 1$. When using $MOP(19) = 1$, the second primary variable upon initialization can also be relative humidity RH , expressed as a fraction ($0 < RH \leq 1$); this choice is made by entering the second primary variable as a negative number, which will serve as a flag to indicate that it means (negative of) relative humidity, and will be internally converted to saturation in the initialization phase. The conversion consists of iteratively solving Kelvin's equation for given $RH = f_{VPL}(T, S_l)$ for S_l . Users need to beware that relative humidity specifications must be within the range that is feasible for the capillary pressure functions used. If maximum capillary pressures are not strong enough to accommodate a chosen value of RH , a diagnostic will be printed and execution will terminate.

Table 7. Summary of EOS4

<u>Components</u>	# 1: water # 2: air
<u>Parameter choices</u>	
$(NK, NEQ, NPH, NB) =$	(2, 3, 2, 6) water and air, nonisothermal (default) (1, 2, 2, 6) water only (no air), nonisothermal
	<ul style="list-style-type: none"> • $MOP(20) = 1$ optionally suppresses vapor pressure lowering effects • molecular diffusion can be modeled by setting $NB = 8$
<u>Primary Variables</u> *†	
single-phase conditions	(P, T, P_a) - (pressure, temperature, air partial pressure)
two-phase conditions	(P_g, S_g, P_a) - (gas phase pressure, gas saturation, air partial pressure)

* By setting $MOP(19) = 1$, initialization of two-phase conditions can be made with (P_g, S_g, T) , or with $(P_g, -RH, T)$, where RH is relative humidity ($0 < RH \leq 1$).

† By setting $MOP(19) = 2$, initialization can be made with EOS3-style variables (P, X, T) for single-phase (X is air mass fraction), $(P_g, S_g + 10, T)$ for two-phase.

As a further convenience to users, the choice $MOP(19) = 2$ allows EOS4 to be initialized with EOS3 variables of (P, X, T) for single-phase, $(P_g, S_g + 10, T)$ for two-phase. This way continuation runs with EOS4 can be made from EOS3-generated conditions. Note that, when using $MOP(19) \neq 0$ options, data block or file INCON must terminate on a blank record (' '). If '+++' is encountered in INCON, it is assumed that primary variables are provided in agreement with internal usage; $MOP(19)$ is then reset to zero and an informative message is printed.

Vapor pressure lowering effects raise new issues because they make it possible for a liquid phase to exist under conditions where vapor partial pressure and gas phase total pressure are less than the saturation pressure. What is the appropriate pressure at which liquid phase density, enthalpy and viscosity are to be evaluated? We believe that a physically plausible choice is to take $P_l = \max(P_g, P_{sat})$, and this has been implemented in EOS4. The implementation faces a difficulty, however, because temperature is not among the primary variables in two-phase conditions, so that P_{sat} is only implicitly known; moreover, vapor pressure lowering effects are functionally dependent on liquid phase density, which is also a function of temperature. This leads to a potentially unstable situation with regard to the choice of liquid phase pressure under conditions where $P_g \approx P_{sat}$, which happens to be a common occurrence in boiling regions. In order to avoid this problem we evaluate liquid water density in the Kelvin equation for vapor pressure lowering (Eq. 1) always at $P_l = P_{sat}$, which will be an excellent approximation due to the small compressibility of liquid water. In all accumulation and flow terms the density of liquid water is evaluated at $P_l = \max(P_g, P_{sat})$. Vapor pressure lowering can be optionally suppressed by setting $MOP(20) = 1$.

3. Sample Problems

3.1. Problem No. 1 (*eos4p1*) - Code Demonstration

This problem demonstrates various initialization options and phase transitions. A number of one- and two-element subproblems are simulated which are entirely independent of each other (no flow connections between subproblems), except that being run together they all must go through the same sequence of time steps. The input file for running with the EOS4 fluid properties module is given in Figure 1. Parameter *MOP(19)* in the first record of data block **PARAM** was set equal to 1, to permit initialization of the EOS4 module with the primary variables of (P_g , S_g , T) for two-phase. Data block **OUTPUT** is used to select variables to print out, and Figure 2 shows the printed output in the CSV format.

```

*eos4p1* CODE DEMONSTRATION: PHASE TRANSITIONS
ROCKS----1----*----2----*----3----*----4----*----5----*----6----*----7----*----8
TRANS      2650.      .50      1.E-14      2.10      1000.

START----1----*----2----*----3----*----4----*----5----*----6----*----7----*----8
----*----1 MOP: 123456789*123456789*1234 ----*----5----*----6----*----7----*----8
PARAM----1----*----2----*----3----*----4----*----5----*----6----*----7----*----8
      2      5      1100 30 000000000711
              -1.
      1.E-8      1.E2      5.E3
              45.E5      .5      250.

RPCAP----1----*----2----*----3----*----4----*----5----*----6----*----7----*----8
      3      .30      .05
      1      1.E8      .2      1.
ELEME----1----*----2----*----3----*----4----*----5----*----6----*----7----*----8
F 1 4 1TRANS 10.

CONNE----1----*----2----*----3----*----4----*----5----*----6----*----7----*----8
F 1F 2 1 5. 5. 1.
F 3F 4 1 5. 5. 1.

INCON----1----*----2----*----3----*----4----*----5----*----6----*----7----*----8
F 1
      1.E5      20.      1.E5
F 2
      1.E6      170.      1.E5
F 3
      1.E5      .001      99.5
F 4
      99.E5      .999      310.
F 5
      1.E7      0.1      300.

GENER----1----*----2----*----3----*----4----*----5----*----6----*----7----*----8
F 5WEL 1 MASS -1.5E-2

OUTPU----1----*----2----*----3----*----4----*----5----*----6----*----7----*----8
      4
PRESSURE
TEMPERATURE
SATURATION      2
MASS FRACTION      1 1

ENDCY----1----*----2----*----3----*----4----*----5----*----6----*----7----*----8

```

Figure 17. Input file for problem eos4p1.

"	ELEM", "	PRES", "	TEMP", "	SAT_L", "	X_WATER_G"
"	"", "	(PA)", "	(DEC-C)", "	(-)", "	(-)"
"TIME [sec]	0.10000000E-07"				
"	F0001",	0.100000000000E+06,	0.200000000000E+02,	0.000000000000E+00,	0.000000000000E+00
"	F0002",	0.100000000000E+07,	0.170000000000E+03,	0.100000000000E+01,	0.839883835971E+00
"	F0003",	0.100000000000E+06,	0.995000000000E+02,	0.999000000000E+00,	0.991393765580E+00
"	F0004",	0.990000000000E+07,	0.310000000000E+03,	0.100000000000E-02,	0.506799325985E+00
"	F0005",	0.100000000000E+08,	0.300000000000E+03,	0.900000000000E+00,	0.777541482195E+00
"TIME [sec]	0.15625000E+01"				
"	F0001",	0.101148055597E+06,	0.200378745563E+02,	0.180274261457E-03,	0.690294530941E-02
"	F0002",	0.891011731296E+06,	0.169991401635E+03,	0.999858423776E+00,	0.840877784656E+00
"	F0003",	0.108916342598E+06,	0.995009229488E+02,	0.998912805044E+00,	0.869093654928E+00
"	F0004",	0.989826551186E+07,	0.309974602582E+03,	0.113393558246E-02,	0.506703821429E+00
"	F0005",	0.999983895103E+07,	0.299999899584E+03,	0.899993247272E+00,	0.777550023536E+00
"TIME [sec]	0.79687500E+02"				
"	F0001",	0.103004357151E+06,	0.222282874242E+02,	0.948284070649E-02,	0.779885467717E-02
"	F0002",	0.849433347813E+06,	0.169975240017E+03,	0.989471696916E+00,	0.891149731446E+00
"	F0003",	0.472599430089E+06,	0.995441859916E+02,	0.994575266222E+00,	0.143855642371E+00
"	F0004",	0.981226192764E+07,	0.308712734196E+03,	0.779587864763E-02,	0.501955136821E+00
"	F0005",	0.999180292384E+07,	0.299994883389E+03,	0.899655584989E+00,	0.777976164318E+00
"TIME [sec]	0.17734375E+03"				
"	F0001",	0.105319381033E+06,	0.248349083563E+02,	0.209293255162E-01,	0.898561981198E-02
"	F0002",	0.822703019191E+06,	0.169957142366E+03,	0.976695169277E+00,	0.921371345058E+00
"	F0003",	0.771118118502E+06,	0.995924238921E+02,	0.989204426301E+00,	0.851811311317E-01
"	F0004",	0.970744716586E+07,	0.307161011336E+03,	0.160112109802E-01,	0.496080834195E+00
"	F0005",	0.998180306128E+07,	0.299988625360E+03,	0.899233434244E+00,	0.778506276953E+00
"TIME [sec]	0.29941406E+03"				
"	F0001",	0.108210275266E+06,	0.279039240421E+02,	0.349620354856E-01,	0.105641433490E-01
"	F0002",	0.801963083372E+06,	0.169936035560E+03,	0.961052321718E+00,	0.941080712065E+00
"	F0003",	0.101490041983E+07,	0.996471469813E+02,	0.982542508687E+00,	0.637495993336E-01
"	F0004",	0.958086542209E+07,	0.305262897771E+03,	0.261026373277E-01,	0.488836820708E+00
"	F0005",	0.996937309464E+07,	0.299980821721E+03,	0.898705633475E+00,	0.779164946145E+00

Figure 2. Printed output variables in CSV format based on **OUTPUT** block shown in Figure 1.

3.2.Problem No. 2 (*rhp*) - Heat Pipe in Cylindrical Geometry

Heat pipes are systems in which an efficient heat transfer takes place by means of a liquid-vapor counterflow process, with vaporization and condensation occurring at the hot and cold ends, respectively. Heat pipe processes occur naturally on a large scale (kilometers) in two-phase geothermal reservoirs, and they may be induced artificially if heat-generating nuclear waste packages are emplaced above the water table in partially saturated geologic formations.

The present problem models such high-level nuclear waste emplacement in an approximate way. The input file shown in Figure 3 specifies a cylindrical heater of 0.3 m radius and 4.5 m height, that provides a constant output of 3 kW into a porous medium with uniform initial conditions of 18 °C temperature, 1 bar pressure, and 20 % gas saturation. The MESHMAKER module is used to generate a one-dimensional radial grid of 120 active elements extending to a radius of 10,000 m (practically infinite for the time scales of interest here), with an additional element of a very large volume representing constant boundary conditions. Properly speaking, the problem represents one unit of an infinite linear string of identical heaters; if a single heater were to be modeled, important end effects would occur at the top and bottom, and a two-dimensional R-Z grid would have to be used.

```

*rbp* 1-D RADIAL HEAT PIPE
MESHMAKER1-----2-----3-----4-----5-----6-----7-----8
RZ2D
RADII
  1
    0.
EQUID
  1          .3
LOGAR
  99          1.E2
LOGAR
  20          1.E4
LAYER-----1-----2-----3-----4-----5-----6-----7-----8
  1
    4.5
ROCKS-----1-----2-----3-----4-----5-----6-----7-----8
POMED   1      2550.      .10  20.E-15  20.E-15  20.E-15      2.0    800.0
              .25
MULTI-----1-----2-----3-----4-----5-----6-----7-----8
  2   3   2   6
START-----1-----2-----3-----4-----5-----6-----7-----8
----*-----1 MOP: 123456789*123456789*1234 ----*-----5-----6-----7-----8
PARAM-----1-----2-----3-----4-----5-----6-----7-----8
  2 250      25010003000000000 47 1 6              1.80
          3.15576E8             -1.
          1.E3           9.E3           9.E4           4.E5
          1.E-5          1.E00              1.E-7
          1.E5              0.20              18.
diffusivity data are input as follows:
first row water, second row air; first column gas, second column aqueous
DIFFU-----1-----2-----3-----4-----5-----6-----7-----8
  2.13e-5      0.e-8
  2.13e-5      0.e-8
RPCAP-----1-----2-----3-----4-----5-----6-----7-----8
  7           0.45000      9.6E-4           1.
  7           0.45000      1.0E-3           8.0E-05          5.E8           1.
TIMES-----1-----2-----3-----4-----5-----6-----7-----8
  3
  3.15576E7  1.2559E8  3.15576E8
INCON-----1-----2-----3-----4-----5-----6-----7-----8
GENER-----1-----2-----3-----4-----5-----6-----7-----8
A1 1HTR 1              HEAT          3.E3
OUTPU-----1-----2-----3-----4-----5-----6-----7-----8
  4
PRESSURE
TEMPERATURE
SATURATION          2
MASS FRACTION      1   2
ENDCY-----1-----2-----3-----4-----5-----6-----7-----8

```

Figure 3. Input file for problem 2 – heat pipe in cylindrical geometry.

Most of the formation parameters are identical to data used in previous modeling studies of high-level nuclear waste emplacement at Yucca Mountain (Pruess et al., 1990). As we do not include fracture effects in the present simulation, heat pipe effects would be very weak at the low rock matrix permeabilities (of order 1 microdarcy) encountered at Yucca Mountain. To get a more interesting behavior, we have arbitrarily increased absolute permeability by something like a factor 10,000, to 20 millidarcy, and for consistency have reduced capillary pressures by a factor $(10,000)^{1/2} = 100$ in comparison to typical Yucca Mountain data.

It is well known that for the stated conditions (1-D radial geometry, homogeneous medium, uniform initial conditions, and a constant-rate line source) the problem has a similarity solution: The partial differential equations for this complex two-phase flow problem can be rigorously transformed into a set of ordinary differential equations in the variable $Z = R\sqrt{t}$, which can be easily solved to any degree of accuracy desired by means of one-dimensional numerical integration (O'Sullivan, 1981). Comparison of TOUGH3 simulations with the semi-analytical similarity solution has shown excellent agreement (Doughty and Pruess, 1992). Figure 4 gives simulation results after $t = 10$ yr obtained with EOS4, including vapor pressure lowering, plotted as a function of the natural logarithm of the similarity variable Z .

To provide a benchmark for proper code installation, we present portions of the printed output. Figure 5 shows part of the iteration sequence and thermodynamic data after $t = 1$ yr for running the input file as given in Figure 3. Note TOUGH3 printed out only the variables selected in data block **OUTPU**. Although maximum temperatures exceed saturated vapor temperatures at prevailing pressures, none of the grid blocks dry out because of vapor pressure lowering effects. The input file in Figure 3 includes data for vapor-air diffusion, which can be engaged by changing parameter NB in data block **MULTI** from 6 to 8. Some of the output when diffusion is included is shown in Figure 6. Comparison with Figure 5 shows that some air remains in the boiling region near the heater when diffusion is active. Vapor is removed from the hot region at somewhat larger rates, causing liquid saturations to be somewhat smaller. This makes the heat pipe less efficient, and leads to slightly higher temperatures.

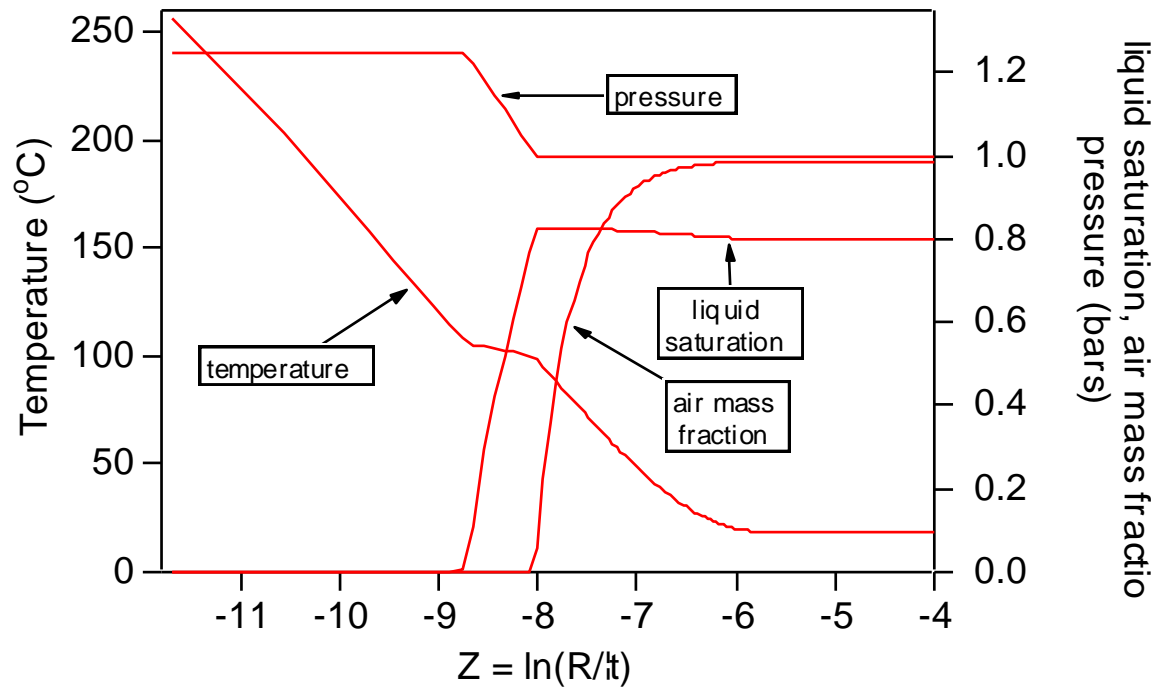

Figure 4. Profiles of temperature, pressure, liquid saturation and air mass fraction.

```

...ITERATING... AT [ 1, 1] --- DELTEX = 0.100000E+04 MAX. RES. = 0.603498E-01 AT ELEMENT A1001 EQUATION 3
...ITERATING... AT [ 1, 2] --- DELTEX = 0.100000E+04 MAX. RES. = 0.170197E-02 AT ELEMENT A1001 EQUATION 3
A1001( 1, 3) ST = 0.100000E+04 DT = 0.100000E+04
...ITERATING... AT [ 2, 1] --- DELTEX = 0.900000E+04 MAX. RES. = 0.502677E+00 AT ELEMENT A1001 EQUATION 3
...ITERATING... AT [ 2, 2] --- DELTEX = 0.900000E+04 MAX. RES. = 0.865621E-01 AT ELEMENT A1001 EQUATION 3
...ITERATING... AT [ 2, 3] --- DELTEX = 0.900000E+04 MAX. RES. = 0.297245E-02 AT ELEMENT A1001 EQUATION 3
A1001( 2, 4) ST = 0.100000E+05 DT = 0.900000E+04
...ITERATING... AT [ 3, 1] --- DELTEX = 0.900000E+05 MAX. RES. = 0.300127E+01 AT ELEMENT A1001 EQUATION 3
...ITERATING... AT [ 3, 2] --- DELTEX = 0.900000E+05 MAX. RES. = 0.140737E+01 AT ELEMENT A1001 EQUATION 3
...ITERATING... AT [ 3, 3] --- DELTEX = 0.900000E+05 MAX. RES. = 0.341483E+00 AT ELEMENT A1001 EQUATION 3
...ITERATING... AT [ 3, 4] --- DELTEX = 0.900000E+05 MAX. RES. = 0.212692E-01 AT ELEMENT A1001 EQUATION 3
...ITERATING... AT [ 3, 5] --- DELTEX = 0.900000E+05 MAX. RES. = 0.840009E-04 AT ELEMENT A1001 EQUATION 3
A1001( 3, 6) ST = 0.100000E+06 DT = 0.900000E+05
...ITERATING... AT [ 4, 1] --- DELTEX = 0.400000E+06 MAX. RES. = 0.252316E+01 AT ELEMENT A1001 EQUATION 3
...ITERATING... AT [ 4, 2] --- DELTEX = 0.400000E+06 MAX. RES. = 0.109933E+01 AT ELEMENT A1001 EQUATION 3
...ITERATING... AT [ 4, 3] --- DELTEX = 0.400000E+06 MAX. RES. = 0.574588E+00 AT ELEMENT A1001 EQUATION 3
...ITERATING... AT [ 4, 4] --- DELTEX = 0.400000E+06 MAX. RES. = 0.106401E+02 AT ELEMENT A1001 EQUATION 2
...ITERATING... AT [ 4, 5] --- DELTEX = 0.400000E+06 MAX. RES. = 0.215196E+01 AT ELEMENT A1001 EQUATION 2
...ITERATING... AT [ 4, 6] --- DELTEX = 0.400000E+06 MAX. RES. = 0.198631E+00 AT ELEMENT A1001 EQUATION 2
...ITERATING... AT [ 4, 7] --- DELTEX = 0.400000E+06 MAX. RES. = 0.245616E-02 AT ELEMENT A1001 EQUATION 2
A1001( 4, 8) ST = 0.500000E+06 DT = 0.400000E+06
...ITERATING... AT [ 5, 1] --- DELTEX = 0.400000E+06 MAX. RES. = 0.489499E+00 AT ELEMENT A1002 EQUATION 3
...ITERATING... AT [ 5, 2] --- DELTEX = 0.400000E+06 MAX. RES. = 0.123191E+02 AT ELEMENT A1001 EQUATION 1
...ITERATING... AT [ 5, 3] --- DELTEX = 0.400000E+06 MAX. RES. = 0.248705E+01 AT ELEMENT A1001 EQUATION 1
...ITERATING... AT [ 5, 4] --- DELTEX = 0.400000E+06 MAX. RES. = 0.200125E+00 AT ELEMENT A1001 EQUATION 1
...ITERATING... AT [ 5, 5] --- DELTEX = 0.400000E+06 MAX. RES. = 0.120495E-02 AT ELEMENT A1001 EQUATION 1
A1001( 5, 6) ST = 0.900000E+06 DT = 0.400000E+06
...ITERATING... AT [ 6, 1] --- DELTEX = 0.400000E+06 MAX. RES. = 0.502016E+00 AT ELEMENT A1001 EQUATION 1
...ITERATING... AT [ 6, 2] --- DELTEX = 0.400000E+06 MAX. RES. = 0.227700E+01 AT ELEMENT A1001 EQUATION 1
...ITERATING... AT [ 6, 3] --- DELTEX = 0.400000E+06 MAX. RES. = 0.381741E-01 AT ELEMENT A1001 EQUATION 1
...ITERATING... AT [ 6, 4] --- DELTEX = 0.400000E+06 MAX. RES. = 0.556358E-04 AT ELEMENT A1001 EQUATION 1
A1001( 6, 5) ST = 0.130000E+07 DT = 0.400000E+06
...ITERATING... AT [ 7, 1] --- DELTEX = 0.400000E+06 MAX. RES. = 0.172437E+00 AT ELEMENT A1001 EQUATION 1
...ITERATING... AT [ 7, 2] --- DELTEX = 0.400000E+06 MAX. RES. = 0.974437E+00 AT ELEMENT A1001 EQUATION 1
...ITERATING... AT [ 7, 3] --- DELTEX = 0.400000E+06 MAX. RES. = 0.265585E-02 AT ELEMENT A1001 EQUATION 1
A1001( 7, 4) ST = 0.170000E+07 DT = 0.400000E+06
...ITERATING... AT [ 8, 1] --- DELTEX = 0.800000E+06 MAX. RES. = 0.245244E+00 AT ELEMENT A1005 EQUATION 3
...ITERATING... AT [ 8, 2] --- DELTEX = 0.800000E+06 MAX. RES. = 0.326186E+01 AT ELEMENT A1001 EQUATION 1
...ITERATING... AT [ 8, 3] --- DELTEX = 0.800000E+06 MAX. RES. = 0.326622E+01 AT ELEMENT A1002 EQUATION 2
...ITERATING... AT [ 8, 4] --- DELTEX = 0.800000E+06 MAX. RES. = 0.684807E+00 AT ELEMENT A1002 EQUATION 2
...ITERATING... AT [ 8, 5] --- DELTEX = 0.800000E+06 MAX. RES. = 0.786181E-01 AT ELEMENT A1002 EQUATION 2
...ITERATING... AT [ 8, 6] --- DELTEX = 0.800000E+06 MAX. RES. = 0.175000E-02 AT ELEMENT A1002 EQUATION 2
.....
.....
A1002( 27, 6) ST = 0.305000E+08 DT = 0.160000E+07
...ITERATING... AT [ 28, 1] --- DELTEX = 0.105760E+07 MAX. RES. = 0.160794E+00 AT ELEMENT A1002 EQUATION 1
...ITERATING... AT [ 28, 2] --- DELTEX = 0.105760E+07 MAX. RES. = 0.302789E+02 AT ELEMENT A1002 EQUATION 1
...ITERATING... AT [ 28, 3] --- DELTEX = 0.105760E+07 MAX. RES. = 0.358474E+01 AT ELEMENT A1002 EQUATION 1
...ITERATING... AT [ 28, 4] --- DELTEX = 0.105760E+07 MAX. RES. = 0.451983E-01 AT ELEMENT A1002 EQUATION 1
A1002( 28, 5) ST = 0.315576E+08 DT = 0.105760E+07
*rhpf 1-D RADIAL HEAT PIPE

OUTPUT DATA AFTER ( 28, 5)-2-TIME STEPS THE TIME IS 0.365250E+03 DAYS
#####
TOTAL TIME KCYC ITER ITERC KON DX1M DX2M DX3M MAX. RES. NER KER DELTEX
0.315576E+08 28 5 163 2 0.68692E+03 0.19044E-01 0.26355E+04 0.91107E-05 2 1 0.10576E+07
#####
ELEM. INDEX PRES TEMP SAT_L X_AIR_G
(PA) (DEC-C) (-) (-)
ELEM. INDEX PRES TEMP SAT_L X_AIR_G
(PA) (DEC-C) (-) (-)
A1001 1 0.14349E+06 0.1675E+03 0.1259E-02 0.1976E-15
A1002 2 0.14349E+06 0.1139E+03 0.3219E-02 0.2629E-21
A1003 3 0.12974E+06 0.1071E+03 0.1384E+00 0.3686E-20
A1004 4 0.11847E+06 0.1044E+03 0.3906E+00 0.2884E-15
A1005 5 0.10947E+06 0.1022E+03 0.5869E+00 0.2643E-10
A1006 6 0.10179E+06 0.1001E+03 0.7771E+00 0.2654E-05
A1007 7 0.10004E+06 0.9262E+02 0.8262E+00 0.3173E+00
A1008 8 0.10004E+06 0.8464E+02 0.8250E+00 0.5457E+00
A1009 9 0.10004E+06 0.7770E+02 0.8239E+00 0.6779E+00
A1010 10 0.10004E+06 0.7156E+02 0.8228E+00 0.7616E+00
A1011 11 0.10004E+06 0.6610E+02 0.8217E+00 0.8178E+00
A1012 12 0.10004E+06 0.6119E+02 0.8206E+00 0.8572E+00
A1013 13 0.10004E+06 0.5677E+02 0.8195E+00 0.8857E+00
A1014 14 0.10004E+06 0.5276E+02 0.8185E+00 0.9069E+00
A1015 15 0.10004E+06 0.4912E+02 0.8174E+00 0.9229E+00
A1016 16 0.10004E+06 0.4581E+02 0.8164E+00 0.9353E+00
A1017 17 0.10004E+06 0.4279E+02 0.8153E+00 0.9449E+00
A1018 18 0.10004E+06 0.4005E+02 0.8143E+00 0.9526E+00
A1019 19 0.10004E+06 0.3756E+02 0.8133E+00 0.9587E+00
A1020 20 0.10004E+06 0.3529E+02 0.8123E+00 0.9636E+00
.....
.....

```

Figure 5. Selected output for problem 2 run.

References

- Doughty, C. and K. Pruess. A Similarity Solution for Two-Phase Water, Air and Heat Flow Near a Linear Heat Source in a Porous Medium, *J. of Geophys. Res.*, 97 (B2), 1821-1838, 1992.
- Edlefsen, N.E. and A.B.C. Anderson. Thermodynamics of Soil Moisture, *Hilgardia*, 15 (2), 31–298, 1943.
- O’Sullivan, M.J. A Similarity Method for Geothermal Well Test Analysis, *Water Resour. Res.*, Vol. 17, No. 2, pp. 390 – 398, 1981.
- Pruess, K., J.S.Y. Wang and Y.W. Tsang. On Thermohydrological Conditions Near High-Level Nuclear Wastes Emplaced in Partially Saturated Fractured Tuff. Part 2. Effective Continuum Approximation, *Water Resour. Res.*, Vol. 26, No. 6, pp. 1249 - 1261, 1990.

EOS5: An Equation-of-State Module for Water, Hydrogen

Yoojin Jung
George Pau
Stefan Finsterle

Earth Sciences Division, Lawrence Berkeley National Laboratory
University of California, Berkeley, California 94720

1. Description

The EOS5 fluid property module is developed to study the behavior of groundwater systems in which hydrogen releases take place. For instance, in a number of waste disposal projects, corrosive metals are to be emplaced in geologic formations beneath the water table. These will evolve a mixture of gases, with hydrogen being the chief constituent. EOS5 is a close “cousin” of EOS3, the main difference being that the air component is replaced by hydrogen, with considerably different thermophysical properties (see Table 1). The assignment and handling of primary thermodynamic variables in EOS5 is identical to EOS3 (see Table 2). The main differences in the assignment of secondary parameters are as follows. Density of gaseous hydrogen is computed from the ideal gas law. Viscosity and water solubility of hydrogen are interpolated from the data given in Table 1. For temperatures in excess of 25 °C, the solubility at 25 °C is used.

Table 1. Thermophysical properties of hydrogen

density at $P = 1$ bar	experimental*	ideal gas law†
$T = 280$ K	0.086546 kg/m ³	0.08660 kg/m ³
$T = 300$ K	0.080776 kg/m ³	0.08082 kg/m ³
viscosity*	$T = 0$ °C	$T = 100$ °C
$P = 1$ bar	8.40x10 ⁻⁶ Pa·s	10.33x10 ⁻⁶ Pa·s
$P = 100$ bar	8.57x10 ⁻⁶ Pa·s	10.44x10 ⁻⁶ Pa·s
solubility in water at $P = 1$ bar§	$T = 0$ °C	1.92x10 ⁻⁶ g H ₂ /g H ₂ O
	$T = 25$ °C	1.54x10 ⁻⁶ g H ₂ /g H ₂ O

* from Vargaftik (1975), p. 39.

† universal gas constant $R = 8314.56$ J/mol°C; molecular weight of hydrogen 2.0160 kg/mol.

§ after Dean (1985); solubility at different pressures is computed from Henry’s law.

2. Specifications

A summary of EOS5 specifications and parameters is given in Table 2. The default parameter settings are $(NK, NEQ, NPH, NB) = (2, 3, 2, 6)$. The option $NEQ = 2$ is available for constant temperature conditions. The choice of primary thermodynamic variables is (P, X, T) for single-phase, $(P_g, S_g + 10, T)$ for two-phase conditions. As a convenience to users, we retain the capability to optionally initialize flow problems with TOUGH-style primary variables by setting $MOP(19) = 1$. In TOUGH we have (P, T, X) for single-phase conditions, (P_g, S_g, T) for two-phase conditions.

Table 2. Summary of EOS3

<u>Components</u>	# 1: water # 2: hydrogen
<u>Parameter choices</u>	$(NK, NEQ, NPH, NB) =$ (2, 3, 2, 6) water and hydrogen, nonisothermal (default) (2, 2, 2, 6) water and hydrogen, isothermal molecular diffusion can be modeled by setting $NB = 8$
<u>Primary Variables</u> *	single-phase conditions (P, X, T) - (pressure, hydrogen mass fraction, temperature) two-phase conditions $(P_g, S_g + 10, T)$ - (gas phase pressure, gas saturation plus 10, temperature)

* By setting $MOP(19) = 1$, initialization can be made with TOUGH-style variables (P, T, X) for single-phase, (P_g, S_g, T) for two-phase.

3. Sample Problem (*eos5p1*) - Code Demonstration

This problem is prepared to demonstrate various initialization options of the EOS5 property module. A number of one- and two-element subproblems are simulated which are entirely independent of each other (no flow connections between subproblems), except that being run together they all must go through the same sequence of time steps. The input file for running with the EOS5 fluid properties module is given in Figure 1. Parameter $MOP(19)$ in the first record of data block **PARAM** was set equal to 1, to permit initialization of the EOS5 module with TOUGH-style primary variables of (P, T, X) for single phase, (P_g, S_g, T) for two-phase. Data block **OUTPU** is used to select variables to print out. Figure 2 shows the printed output data. The input file is also run with the EOS3 module to show the difference between two modules (air vs. hydrogen), and Figure 3 shows the printout from the EOS3 run. Due to the considerably lower density, viscosity, and solubility of hydrogen, the pressure, saturation, and mass fractions in each phase in Figure 2 are quite different from those in Figure 3.

```

*eos5p1* CODE DEMONSTRATION: PHASE TRANSITIONS, COMPONENT (DIS-)APPEARANCES
ROCKS-----1-----*-----2-----*-----3-----*-----4-----*-----5-----*-----6-----*-----7-----*-----8
TRANS          2650.          .50      1.E-14                                2.10      1000.

START-----1-----*-----2-----*-----3-----*-----4-----*-----5-----*-----6-----*-----7-----*-----8
-----*-----1 MOP: 123456789*123456789*123456789*1234 -----*-----5-----*-----6-----*-----7-----*-----8
PARAM-----1-----*-----2-----*-----3-----*-----4-----*-----5-----*-----6-----*-----7-----*-----8
      2      1          1100 30 000000000711
                                -1.
      1.E2

                                45.E5                                .5                                250.
RPCAP-----1-----*-----2-----*-----3-----*-----4-----*-----5-----*-----6-----*-----7-----*-----8
      3          .30          .05
      1          1.
ELEME-----1-----*-----2-----*-----3-----*-----4-----*-----5-----*-----6-----*-----7-----*-----8
F 1      7      1TRANS      10.

CONNE-----1-----*-----2-----*-----3-----*-----4-----*-----5-----*-----6-----*-----7-----*-----8
F 1F 2          1          5.          5.          1.
F 3F 4          1          5.          5.          1.
F 5F 6          1          5.          5.          1.

INCON-----1-----*-----2-----*-----3-----*-----4-----*-----5-----*-----6-----*-----7-----*-----8
F 1
F 2          1.E5          20.          1.
F 3          1.E6          170.          0.
F 4          1.E5          .001          99.5
F 5          99.E5          .999          310.
F 6          1.E6          100.          0.
F 7          10.E6          100.          1.
F 8          1.E5          20.          0.
F 8          1.E5          .99          90.

GENER-----1-----*-----2-----*-----3-----*-----4-----*-----5-----*-----6-----*-----7-----*-----8
F 7AIR 1          COM2          5.E-3      9.882E4
F 8HOT 1          HEAT          2.E6

OUTPU-----1-----*-----2-----*-----3-----*-----4-----*-----5-----*-----6-----*-----7-----*-----8
      7
PRESSURE
TEMPERATURE
SATURATION          2
MASS FRACTION          1      1
MASS FRACTION          1      2
MASS FRACTION          2      1
MASS FRACTION          2      2

ENDCY-----1-----*-----2-----*-----3-----*-----4-----*-----5-----*-----6-----*-----7-----*-----8

```

Figure 18. Input file for problem eos5p1.

References

Dean, J.A. (ed.). *Lange's Handbook of Chemistry*, McGraw Hill, Thirteenth Edition, New York, 1985.

Vargaftik, N.B. *Tables on the Thermophysical Properties of Liquids and Gases*, 2nd Ed., John Wiley & Sons, New York, NY, 1975.

EOS7: An Equation-of-State Module for Water, Brine, Air

Yoojin Jung
George Pau
Stefan Finsterle

Earth Sciences Division, Lawrence Berkeley National Laboratory
University of California, Berkeley, California 94720

1. Description

An extension of the EOS3 module for water/air mixtures, EOS7 represents the aqueous phase as a mixture of (pure) water and brine. This approach is very useful for flow problems in which salinity does not reach saturated levels (Reeves et al., 1986; Herbert et al., 1988). The salinity of the aqueous phase is described by means of the brine mass fraction, X_b , and density and viscosity are interpolated from the values for the water and brine endmembers. Salinity-dependent air solubility is also taken into account, but no allowance is made for reduction of vapor pressure with salinity. The brine is modeled as NaCl solution, while the non-condensable gas is air, although the treatment could be adapted, with minor modifications, to other brines and gases. The representation of the temperature and pressure dependence of thermophysical properties is somewhat more general than that of Reeves et al. (1986), retaining the flexibility of the TOUGH3 formulation for nonisothermal processes.

EOS7 can describe phase conditions ranging from single-phase liquid to two-phase to single-phase gas. However, the approach of describing variably saline fluids not as mixtures of water and salt but as mixtures of water and brine has specific limitations which need to be considered in applications. For example, in problems with significant boiling it would be possible for salinity to reach saturated levels, corresponding to brine mass fraction $X_b = 1$ (supposing that the brine component was chosen as fully saturated salt solution). Upon further boiling solid salt would precipitate, but solubility limits and solids precipitation are not taken into account in the approach used in EOS7. (These can be modeled with the EWASG module, see the addendum for EWASG.) As evaporation continues from a saline aqueous phase, eventually brine mass fraction would increase beyond $X_b = 1$, in which case other mass fractions would become negative, and non-physical results would be obtained. From a physical viewpoint brine mass fraction in the gas phase should always be equal to zero, but the only way the brine mass balance can be maintained during phase transitions from two-phase to single-phase vapor conditions is by allowing $X_{b, \text{gas}}$ to vary freely. Users need to carefully examine problem setups and results to guard against unphysical results in applications that involve boiling.

We now briefly summarize the treatment of thermophysical properties in EOS7. The density of the aqueous phase is calculated from the assumption, shown to be very accurate by Herbert et al. (1988), that fluid volume is conserved when water and brine are mixed. Mixture density ρ_m can then be expressed in terms of water and brine densities as follows.

$$\frac{1}{\rho_m} = \frac{1-X_b}{\rho_w} + \frac{X_b}{\rho_b} \quad (1)$$

where ρ_w and ρ_b are water and brine density, respectively. Eq. 1 applies to densities at fixed pressure and temperature conditions. In order to achieve a simple approximation for fluid density at variable temperatures and pressures, EOS7 takes compressibility and expansivity of brine to be equal to those of water. This will provide a reasonable approximation at least for a limited range of temperatures and pressures around the reference conditions (P_0 , T_0). The default reference brine has a density of 1185.1 kg/m^3 at reference conditions of $P_0 = 1$ bar, $T_0 = 25$ °C, corresponding to an NaCl solution of 24.98 wt-%, or 5.06 molar (Potter and Brown, 1977; cited after Finley and Reeves, 1982). The user may specify different reference conditions and brine densities. Effects of salinity on the enthalpy of the aqueous phase are ignored.

Following Herbert et al. (1988), salinity effects on aqueous phase viscosity are modeled with a polynomial correction to the viscosity of pure water. Mixture viscosity μ_m is represented as follows.

$$\mu_m(P, T, X_b) = \mu_w(P, T) f(X_b) \quad (2)$$

where

$$f(X_b) = 1 + v_1 X_b + v_2 X_b^2 + v_3 X_b^3 \quad (3)$$

with default values of $v_1 = 0.4819$, $v_2 = -0.2774$, and $v_3 = 0.7814$. Different values for the coefficients may be specified by the user.

Gas (air) dissolution in the aqueous phase is modeled by Henry's law, as follows.

$$P_a = K_h x_{aq}^a \quad (4)$$

where K_h is Henry's constant and x_{aq}^a is air mole fraction in the aqueous phase. In saline solutions, gases are generally less soluble than in water ("salting out" effect). For a 5 N (molar) NaCl solution, nitrogen solubility is virtually independent of temperature in the range 0 °C $\leq T \leq 100$ °C, and corresponds to a Henry's constant of $K_h = 4.0 \times 10^{10}$ Pa (Cygan, 1991).

We retain the value of $K_h = 10^{10}$ Pa for pure water, and represent air solubility (inverse of Henry's constant) as a linear function of mixture molarity N_m , as follows.

$$\frac{1}{K_h} = 1.0 \times 10^{-10} + \frac{N_m}{5} \left(\frac{1}{4.0 \times 10^{10}} - 10^{-10} \right) \quad (5)$$

2. Specifications

A summary of EOS7 specifications and parameters appears in Table 1. The default parameter settings are $(NK, NEQ, NPH, NB) = (3, 3, 2, 6)$. The $NK = 2$ (no air) option may only be used for problems with single-phase liquid conditions throughout. The primary variables are (P, X_b, X, T) for single-phase conditions and $(P, X_b, S+I0, T)$ for two-phase conditions, where X is air mass fraction.

Table 8. Summary of EOS7

<u>Components</u>	# 1: water # 2: brine # 3: air (optional) [†]
<u>Parameter choices</u>	$(NK, NEQ, NPH, NB) =$ (3, 3, 2, 6) water, brine, air, isothermal (default) (3, 4, 2, 6) water, brine, air, nonisothermal (2, 2, 2, 6) water, brine, isothermal [†] (2, 3, 2, 6) water, brine, nonisothermal [†] molecular diffusion can be modeled by setting $NB = 8$
<u>Primary Variables</u>	single-phase conditions (P, X_b, X, T) - (pressure, brine mass fraction, air mass fraction, temperature) two-phase conditions ($P, X_b, S+I0, T$) - (gas phase pressure, brine mass fraction, gas saturation plus ten, temperature)

[†] The $NK = 2$ (no air) option may only be used for problems with single-phase liquid conditions throughout.

Users may specify parameters for reference brine in the TOUGH3 input file by means of an optional data block **SELEC**, as follows.

SELEC keyword to introduce a data block with optional reference brine data.

Record **SELEC.1**

Format (I5)

IE(I), I=1,16

IE (1) set equal to 2, to read two additional data records (a larger value with more additional data records is acceptable, but only the first two will be used by EOS7).

Record **SELEC.2**

Format (3E10.4)

P_0, T_0, ρ_b

P_0 reference pressure, Pa

T_0 reference temperature, °C

ρ_b brine density at (P_0, T_0), kg/m³

If any of these parameters is entered as zero, default values of $P_0 = 1$ bar, $T_0 = 25$ °C, $\rho_b = 1185.1$ kg/m³ will be used. For $P_0 < 0$, brine properties will be assumed identical to water.

Record **SELEC.3**

Format (3E10.4)

v_1, v_2, v_3

coefficients for salinity correction of aqueous phase viscosity, see Eq. 3.

3. Sample Problem (*rf1*) - Multiphase and Nonisothermal Processes in a System with Variable Salinity

The problem, involving nonisothermal flow of variably saline brine and air, is not designed with an actual “real life” flow problem in mind; rather, the purpose is to demonstrate the use of a variety of thermodynamic conditions and generation options with EOS7, and to provide a benchmark for proper code implementation.

The input file (see Figure 1) has MESHMAKER specifications for a three-dimensional 5x5x2 X-Y-Z mesh. Data block **MULTI** specifies that the 3-component option (water, brine, air) is to be used in nonisothermal mode ($NK = 3$, $NEQ = 4$), and data block **SELEC** chooses default parameters for the reference brine.

Default initial conditions specified in the last record of data block **PARAM** are: pressure $P = 10^5$ Pa, brine mass fraction $X_b = 0.5$, air mass fraction $X = 0.0$, and temperature $T = 25$ °C. Various different initial conditions are chosen for portions of the flow domain in data block **INCON**. In the top layer, the first row of grid blocks (A11 1 through A11 5) has $X_b = 0.0$, corresponding to single-phase water without salinity; the middle row (A13 1 through A13 5) has $X_b = 0.0$, $X = 0.99$, corresponding to single-phase gas conditions; the last row (A15 1 through A15 5) is initialized with $X_b = 1.0$, corresponding to pure brine. In the bottom layer, two-phase conditions with 50 % gas saturation and different salinities are prescribed for the middle row (grid blocks A23 1 through A23 5). In blocks A23 1 and A23 2 the aqueous phase is pure water, in A23 3 it has 50 % brine mass fraction, and in A23 4 and A23 5 it is 100 % brine.

Generation options (data block **GENER**) include a well on deliverability in the upper left corner of the grid (A11 1), brine injection (COM2) in the upper right hand corner (A11 5), water injection (COM1) in the lower right hand corner (A25 5), heat generation in the center block of the lower layer (A23 3), and air injection (COM3) in the lower left corner (A25 1). Brine enthalpy is 10^6 J/kg, corresponding to a temperature of approximately 233 °C, while enthalpy of injected water, 3×10^5 J/kg, corresponds to a temperature of approximately 72 °C. Air is injected at a lower rate (10^{-4} kg/s) and enthalpy (2×10^5 J/kg). Air specific heat at constant pressure is approximately 1010 J/kg °C (Vargaftik, 1975), so that this enthalpy corresponds to a temperature of approximately 198 °C.

```

*rf1* ... EOS7-test: inject air, heat, brine and fresh water
MESHMAKER1-----*-----2-----*-----3-----*-----4-----*-----5-----*-----6-----*-----7-----*-----8
XYZ

NX          5          1.
NY          5          1.
NZ          2          1.

ROCKS-----1-----*-----2-----*-----3-----*-----4-----*-----5-----*-----6-----*-----7-----*-----8
POMED      2650.          .25  200.e-15  200.e-15  200.e-15          2.2  1000.

....specify three components (water, brine, air); solve energy equation
....no diffusion
MULTI-----1-----*-----2-----*-----3-----*-----4-----*-----5-----*-----6-----*-----7-----*-----8
  3  4  2  6
START-----1-----*-----2-----*-----3-----*-----4-----*-----5-----*-----6-----*-----7-----*-----8
-----*-----1 MOP: 123456789*123456789*1234 -----*-----5-----*-----6-----*-----7-----*-----8
PARAM-----1-----*-----2-----*-----3-----*-----4-----*-----5-----*-----6-----*-----7-----*-----8
  3  99          9910000000000000 4
0.          8.64e4          -1.          9.81
  1.e-9          2.
  1.E-5          1.
          1.e5          0.5          0.0          25.
....use default parameters for reference brine
SELEC-----1-----*-----2-----*-----3-----*-----4-----*-----5-----*-----6-----*-----7-----*-----8
  2

RPCAP-----1-----*-----2-----*-----3-----*-----4-----*-----5-----*-----6-----*-----7-----*-----8
  1          .30          .05          1.          1.
  1          5.e5          .20          1.
TIMES-----1-----*-----2-----*-----3-----*-----4-----*-----5-----*-----6-----*-----7-----*-----8
  3  3
  1.e-9          2.          8.64e4
GENER-----1-----*-----2-----*-----3-----*-----4-----*-----5-----*-----6-----*-----7-----*-----8
A11 1pro 1          DELV          2.e-13          1.e5
A11 5bri 1          COM2          5.e-2          1.e6
A25 5wtr 1          COM1          5.e-2          3.e5
A23 3hot 1          HEAT          1.e5
A25 1air 1          COM3          1.e-4          2.e5

INCON-----1-----*-----2-----*-----3-----*-----4-----*-----5-----*-----6-----*-----7-----*-----8
A11 1  4  1          1.e5          0.00          0.0          25.
A13 1  4  1          1.e5          0.00          0.99          25.
A15 1  4  1          1.e5          1.0          0.0          25.
A23 1  1  1          1.e5          0.00          10.50          25.
A23 3          1.e5          0.50          10.50          25.
A23 4  1  1          1.e5          1.0          10.50          25.

```

Figure 1. TOUGH3 input file for EOS7 test problem.

```

OUTPUT---1---*---2---*---3---*---4---*---5---*---6---*---7---*---8
      8
PRESSURE
TEMPERATURE
SATURATION
MASS FRACTION          2    2
MASS FRACTION          2    3
MASS FRACTION          1    3
CAPILLARY
DENSITY
ENDCY---1---*---2---*---3---*---4---*---5---*---6---*---7---*---8

```

Figure 1. TOUGH3 input file for EOS7 test problem (continued).

The first element-by-element printout occurs at 10^{-9} seconds, giving a record of initial conditions and interblock flow rates. Figure 2 shows the iteration sequence and part of the printout for time step # 2 with $\Delta t = 2$ seconds. Only the printout variables selected in data block **OUTPUT** are shown. The strong suction pressures in the single-phase gas blocks A13 1 through A13 5 have drawn in enough aqueous phase to effect a transition to two-phase conditions. The liquid inflow results in a pressure increase which is very small due to the very large compressibility of gas (approximately $1/P = 10^{-5} \text{ Pa}^{-1}$), while pressure decline in the grid blocks that initially were in single-phase liquid conditions is large, due to the small compressibility of liquid water (of order 10^{-10} Pa^{-1}). Gas phase, mostly air with a small fraction of water vapor, flows from the blocks that were initially in single-phase gas or two-phase conditions into the neighboring single-phase liquid blocks, causing phase transitions to two-phase conditions there. The air injection block A25 1 remains in single-phase liquid conditions, because the amount of air injected in 2 seconds is below the solubility limit at prevailing pressures. Note that brine mass fraction in A13 1 is smaller than in A13 5, due to different aqueous phase compositions in the neighboring blocks that provide the liquid inflows.

With automatic time step control, total desired simulation time of 86,400 seconds (1 day) is reached after 52 time steps. Results are shown in Figure 3. Most of the flow system, except for the vicinity of the block receiving water injection, is now in two-phase conditions. Air is the dominant gas phase component in the cooler regions, while vapor dominates in the hotter regions. Aqueous phase compositions vary over a broad range. X_b exceeds 1 in a few grid blocks, representing a salinity in excess of that of the reference brine. This effect is due to partial vaporization, and indicates limitations in the water-brine mixing approach used in EOS7.

References

- Cygan, R.T. The Solubility of Gases in NaCl Brine and a Critical Evaluation of Available Data, SAND90-2848, Sandia National Laboratories, Albuquerque, New Mexico, 1991.
- Finley, N.C. and M. Reeves. Swift Self-Teaching Curriculum, Report SAND81-0410, Sandia National Laboratory, Albuquerque, NM, 1982.
- Herbert, A.W., C.P. Jackson and D.A. Lever. Coupled Groundwater Flow and Solute Transport with Fluid Density Strongly Dependent on Concentration, *Water Resour. Res.*, Vol. 24, No. 10, pp. 1781 - 1795, 1988.
- Potter, J.M. and D.L. Brown. The Volumetric Properties of Aqueous Sodium Chloride Solutions, U. S. Geological Survey, Bulletin 1421-C, 1977.
- Reeves, M., D. S. Ward, N. D. Johns and R. M. Cranwell. Theory and Implementation of Swift II, The Sandia Waste-Isolation Flow and Transport Model for Fractured Media, Report No. SAND83-1159, Sandia National Laboratory, Albuquerque, NM, 1986.
- Vargaftik, N.B. *Tables on the Thermophysical Properties of Liquids and Gases*, 2nd Ed., John Wiley & Sons, New York, NY, 1975.

EOS7R: An Equation-of-State Module for Water, Brine, radionuclide 1, radionuclide 2, Air

Yoojin Jung
George Pau
Stefan Finsterle

Earth Sciences Division, Lawrence Berkeley National Laboratory
University of California, Berkeley, California 94720

1. Description

This is an enhanced version of the EOS7 module in which two additional mass components have been added, providing radionuclide transport capability for TOUGH3. These components can undergo decay with user-specified half-life, with radionuclide 1 (Rn1 for short) being the “parent” and Rn2 the “daughter.” The radionuclides are considered water-soluble as well as volatile, but are not allowed to form a separate non-aqueous fluid phase. Sorption onto the solid grains is also included. The decaying components are normally referred to as radionuclides, but they may in fact be any trace components that decay, adsorb, and volatilize. The decay process need not to be radioactive decay, but could be any process that follows a first-order decay law, such as biodegradation. Stable trace components, such as volatile and water soluble organic chemicals (VOCs), can be modeled simply by setting half-life to very large values. A detailed description of the mathematical model and numerical implementation used in EOS7R is available in a laboratory report, which also presents a number of illustrative problems, including verification against analytical solutions (Oldenburg and Pruess, 1995). Here we highlight the main aspects of the thermophysical properties model. Note that the current TOUGH3 does not include the dispersion module T2DM, therefore cannot simulate Fickian hydrodynamic dispersion.

Radionuclide decay is described by

$$\frac{dM^\kappa}{dt} = -\lambda_\kappa M^\kappa \quad (1)$$

where M^κ is the mass of radionuclide κ (= Rn1, Rn2) per unit volume, and the decay constant λ_κ is related to the half-life by

$$T_{1/2} = \frac{\ln 2}{\lambda_\kappa} \quad (2)$$

Adsorption of radionuclides on the solid grains is modeled as reversible instantaneous linear sorption, so that mass of radionuclide component κ per unit reservoir volume is given by

$$M^\kappa = \phi \sum_{\beta} S_{\beta} \rho_{\beta} X_{\beta}^{\kappa} + (1 - \phi) \rho_R \rho_{aq} X_{aq}^{\kappa} K_d \quad (3)$$

where K_d is the aqueous phase distribution coefficient (de Marsily, 1986, p. 256).

In addition to adsorbing onto solid matrix grains, the radionuclide components may volatilize into the gas phase, if present. Radionuclides partition between aqueous and gaseous phases according to Henry's law:

$$P_a^\kappa = K_h^\kappa x_{aq}^\kappa \quad (4)$$

where P_a^κ is the partial pressure in the gas phase of radionuclide κ , K_h^κ is Henry's constant and x_{aq}^κ is the mole fraction of radionuclide κ in the aqueous phase. In EOS7R as in EOS7, no solubility constraints are enforced for the brine. Users need to be aware that there are inherent limitations in the ability of a water-brine mixture model to describe processes that involve significant vaporization. Unphysical results may be obtained in thermal problems with strong vaporization effects.

For the gas phase we assume ideal gas law for air and the radionuclides, and additivity of partial pressures.

$$P_{gas} = P_{air} + P_{vapor} + P_{Rn1} + P_{Rn2} \quad (5)$$

Gas phase density is calculated as the sum of the partial densities of gaseous components, while gas phase viscosity and enthalpy are calculated from the same air-vapor mixing models used in EOS3. Apart from these approximations for gas phase viscosity and enthalpy, there is no restriction to "small" radionuclide concentrations in the gas phase, fully allowing gas phase radionuclide partial pressures.

The thermophysical properties of the aqueous phase are assumed independent of radionuclide concentrations. Implicit in this approximation is the assumption that aqueous radionuclide concentrations are small. Users need to keep this limitation in mind, because EOS7R does not provide any intrinsic constraints on radionuclide concentrations.

2. Specifications

A summary of EOS7R specifications and parameters are given in Table 1. The default parameter settings are $(NK, NEQ, NPH, NB) = (5, 5, 2, 8)$. The $NK = 4$ (no air) option may only be used for problems with single-phase liquid conditions throughout. The primary variables are $(P, X_b, X_{Rn1}, X_{Rn2}, X_{air}, T)$ for single-phase conditions and $(P, X_b, X_{Rn1}, X_{Rn2}, S+I0, T)$ for two-phase conditions.

Table 9. Summary of EOS7R

<u>Components</u>	# 1: water # 2: brine # 3: Rn1 (radionuclide 1; “parent”) # 4: Rn2 (radionuclide 2; “daughter”) # 5: air (optional) [†]
<u>Parameter choices</u>	$(NK, NEQ, NPH, NB)^{\S} =$ (5, 5, 2, 8) water, brine, Rn1, Rn2, air, isothermal (default) (5, 6, 2, 8) water, brine, Rn1, Rn2, air, nonisothermal (4, 4, 2, 8) water, brine, Rn1, Rn2, no air, isothermal [†] (4, 5, 2, 8) water, brine, Rn1, Rn2, no air, nonisothermal [†] molecular diffusion can be suppressed by setting $NB = 6$
<u>Primary Variables[§]</u>	single-phase conditions $(P, X_b, X_{Rn1}, X_{Rn2}, X_{air}, T)$ - (pressure, brine mass fraction, mass fraction of Rn1, mass fraction of Rn2, air mass fraction, temperature) two-phase conditions $(P, X_b, X_{Rn1}, X_{Rn2}, S+I0, T)$ - (gas phase pressure, brine mass fraction, mass fraction of Rn1, mass fraction of Rn2, gas saturation plus ten, temperature) [*]

[†] the no air option ($NK = 4$) may only be used for problems with single-phase liquid conditions throughout

[§] parameter $NKIN$ following NB may optionally be set to $NKIN = NK - 2$, in which case radionuclide mass fractions will be omitted, and initialization will be made from only four EOS7-style variables; radionuclide mass fractions will be initialized as zero;

^{*} in two-phase conditions, X_{Rn1} and X_{Rn2} are mass fractions in the aqueous phase

The phase change diagnostics are as follows. For single-phase liquid conditions, Henry's law is used to calculate the partial pressures that the non-condensable gases would have if a gas phase were present. The total pressure that a gas phase would have if present is then calculated from Eq. 5, using saturated vapor pressure at prevailing temperature. This is compared with the aqueous phase pressure, and a transition to two-phase conditions is made when $P_{gas} > P_{aq}$. In two-phase conditions, the saturation variable is monitored. A phase transition to single-phase liquid occurs when $S_g < 0$, while for $S_g > 1$ a transition to single-phase gas conditions is made. For transitions from two-phase to single-phase liquid conditions, liquid pressure is initialized as $P_{aq} = (1 + 10^{-6}) \times P_{gas}$, with P_{gas} given by Eq. 5, while for transitions to single-phase gas conditions, pressure is initialized as $(1 - 10^{-6}) \times P_{gas}$. For single-phase gas conditions we monitor vapor pressure $P_{vap} = P_{gas} - P_{air} - P_{Rn1} - P_{Rn2}$; a transition to two-phase conditions occurs when $P_{vap} > P_{gas}$.

Brine and radionuclide properties are specified in the TOUGH3 input file by means of a data block **SELEC**, as follows.

SELEC keyword to introduce a data block with reference brine, geometry, and radioactive decay data. Note that the current version of TOUGH3 does not include the dispersion module T2DM.

Record **SELEC.1**

Format (16I5)

IE(1), NGBINP(1), NGBINP(2), NGBINP(3), NFBL, NFBR, NFBT, NFBB

IE (1) set equal to 6 to read six additional records with data for brine and radionuclides, and for hydrodynamic dispersion.

The 7 input variables following *IE (1)* are for the dispersion module T2DM only and can be left blank if T2DM is not used.

NGBINP (1) number of grid blocks in X (must always be equal to 1).

NGBINP (2) number of grid blocks in Y.

NGBINP (3) number of grid blocks in Z.

NFBL number of the first ("left") column of grid blocks within the flow domain (defaults to 1 if zero or blank).

<i>NFBR</i>	number of the last ("right") column of grid blocks within the flow domain (defaults to <i>NGBINP</i> (2) if zero or blank).
<i>NFBT</i>	number of the first ("top") row of grid blocks within the flow domain (defaults to 1 if zero or blank).
<i>NFBB</i>	number of the last ("bottom") row of grid blocks within the flow domain (defaults to <i>NGBINP</i> (3) if zero or blank).

Record SELEC.2

Format (3E10.4)

P_0, T_0, ρ_b

P_0	reference pressure, Pa.
T_0	reference temperature, °C.
ρ_b	brine density at (P_0, T_0), kg/m^3 .

If any of these parameters is entered as zero, default values of $P_0 = 1$ bar, $T_0 = 25$ °C, $\rho_b = 1185.1$ kg/m^3 will be used. For $P_0 < 0$, brine properties will be assumed identical to water.

Record SELEC.3

Format (3E10.4)

v_1, v_2, v_3

coefficients for salinity correction of aqueous phase viscosity, following Herbert et al. (1988).

$$f(X_b) = 1 + v_1 X_b + v_2 X_b^2 + v_3 X_b^3 \quad (6)$$

with default values of $v_1 = 0.4819$, $v_2 = -0.2774$, and $v_3 = 0.7814$. Different values for the coefficients may be specified by the user.

Record SELEC.4

Format (2E10.4)

ALPHAT, ALPHAL

Used in T2DM only; otherwise can be left blank.

ALPHAT transverse dispersivity, m.
ALPHAL longitudinal dispersivity, m.

Record **SELEC.5**

Format (6E10.4)
FDDIAG(NP,NK), *NK*=1,2,5; *NP*=1,2

FDDIAG (NP, NK) molecular diffusivities in units of m²/s; first the three gas phase diffusivities for water, brine, and air; then the three aqueous phase diffusivities for water, brine, and air. If a data block **DIFFU** is present, it will override the diffusivity specifications made in **SELEC**.

Record **SELEC.6**

Format (4E10.4, 20X, E10.4)
XHALF(3), XMW(3), (FDDIAG(NP,NK), *NK*=3; *NP*=1,2), HCRN1

XHALF (3) half-life of parent radionuclide (Rn1, component 3), seconds.

XMW (3) molecular weight of Rn1, g/mol.

FDDIAG (NP, 3) molecular diffusivity of Rn1 in the gas phase in m²/s; followed by molecular diffusivity of Rn1 in the aqueous phase. If a data block **DIFFU** is present, it will override the diffusivity specifications made in **SELEC**.

HCRN1 inverse Henry's constant (K_h)⁻¹ (see Eq. 4) for parent radionuclide Rn1, Pa⁻¹. (The inverse Henry's constant can be thought of as an aqueous phase solubility.)

Record **SELEC.7**

Format (4E10.4, 20X, E10.4)
XHALF(4), XMW(4), (FDDIAG(NP,NK), *NK*=4; *NP*=1,2), HCRN2

XHALF (4) half-life of daughter radionuclide (Rn2, component 4), seconds.

XMW (4) molecular weight of Rn2, g/mol.

FDDIAG (NP, 4) molecular diffusivity of Rn2 in the gas phase in m²/s; followed by molecular diffusivity of Rn2 in the aqueous phase. If a data block **DIFFU** is present, it will override the diffusivity specifications made in **SELEC**.

HCRN2 inverse Henry's constant (K_h)⁻¹ (see Eq. 4) for daughter radionuclide Rn2, Pa⁻¹. (The inverse Henry's constant can be thought of as an aqueous phase solubility.)

3. Sample Problems

3.1. Problem No. 1 (*rdif7*) - Thermal and Tracer Diffusion (EOS7R)

This problem is prepared to illustrate thermal and tracer diffusion. Figure 1 shows an input file, which serves as an illustration for preparing EOS7R input data, and as a benchmark for code performance. There are in fact two independent flow problems in two separate 1-D grid systems, each with 1 m² cross sectional area and 2 m long, divided into 20 grid blocks of 0.1 m length. The “A-grid” (blocks A 1 through A 20) is initialized in single phase liquid conditions with default parameters of $P = 10^5$ Pa, $T = 8$ °C, and zero mass fractions for brine, Rn1, Rn2, and air. Boundary conditions provided by block “ina 1” with a very large volume are $(P, X_b, X_{Rn1}, X_{Rn2}, X, T) = (10^5, 10^{-3}, 10^{-7}, 10^{-8}, 10^{-6}, 9$ °C). The radionuclide tracers are stable (half-life of 10⁵⁰ seconds). Rn1 with an inverse Henry’s constant of 10⁵ Pa⁻¹ has low volatility, while Rn2 is a volatile species with the same inverse Henry’s constant as air, 10⁻¹⁰ Pa⁻¹. Diffusivities specified in data block **DIFFU** override parameters in block **SELEC**; all diffusivities are specified as -1.e-6 so that, for all components, mass diffusion occurs with saturation and tortuosity-independent effective diffusivities of 10⁻⁶ m²/s. In addition to mass diffusion, there is also thermal diffusion due to the different temperature at the boundary. Thermal diffusivity is $d_{th} = \lambda/\rho C \approx 2.5/(2500 \times 1000) = 10^{-6}$ m²/s, equal to component diffusivities. Porosity was chosen to be small, $\phi = 10^{-4}$, so that fluid contributions to formation specific heat are small. This parametrization allows a direct comparison between changes for mass fractions and temperatures. The “B-grid” (B 1 through B 20) is initialized in single-phase gas conditions at the same pressure of 10⁵ Pa, but at a temperature of 125 °C, and also with zero mass fractions of all components other than water. Different non-zero mass fractions for the various components are specified in block “ina 2” with a very large volume at the boundary of the B-grid.

Advective effects are suppressed because the medium was assigned zero permeability. Accordingly, the only active processes are mass diffusion of the various components, and thermal diffusion in the A-grid. Portions of the iteration sequence and results obtained after 20 time steps (1.427x10⁶ seconds) are shown in Figure 2. Note that mass fractions for all components are always calculated in both aqueous and gas phases, regardless of phase composition of the fluid (see Section 4.2 in the TOUGH3 user’s guide for further discussion). Under the specified conditions, the diffusive profiles are expected to be the same for all components, the only difference being different normalization, because of the different absolute magnitude of the concentration step at the boundary. The liquid phase mass fraction profiles for brine, Rn1, and Rn2 in the A-grid are seen to be in excellent agreement with each other, as well

as with the temperature profile from heat conduction. The gas phase radionuclide mass fractions listed for the A-grid are obtained from phase partitioning according to Henry's law locally; there is no mass inventory associated with these because gas phase saturations are zero. In the single-phase gas conditions in the B-grid, it is the gas phase mass fractions which are to be compared; for all components they agree very well among each other, as well as with the diffusion profile calculated for the same diffusivities in the single-phase liquid conditions in the A-grid. (Note that for single phase gas conditions, X_BRINE_L is mass fraction in the gas phase.)

```

*rdif7* ... simple diffusion problem for EOS7R
ROCKS----1-----2-----3-----4-----5-----6-----7-----8
SANDY   2      2500.      1.e-4      0.e-12      0.e-12      0.e-12      2.5      1000.
        1.e-8
        1          0.          0.          1.          1.
        1          0.e6         0.          1.

MULTI---1-----2-----3-----4-----5-----6-----7-----8
        5      6      2      8
START---1-----2-----3-----4-----5-----6-----7-----8
----*-----1 MOP: 123456789*123456789*1234 ----*-----5-----*-----6-----*-----7-----*-----8
PARAM---1-----2-----3-----4-----5-----6-----7-----8
        3      20      201 0 0 00 00 0 40 0 1
                -1.      1.e5                        0.00000
        1.e3
        1.E-08      1.e-3
                1.E5                        0.0                        0.0                        0.0
                0.0                        8.0
SELEC---1-----2-----3-----4-----5-----6-----7-----8
        6

        0.e-0      0.e-1
        0.e-6      0.e-6      0.e-6      -1.e-6      -1.e-6      0.e-6
        1.e50      234.0      0.e-6      -1.e-6
        1.e50      230.0      -1.e-6      0.e-6                        1.e+05
                                                1.e-10

diffusivity data are input as follows:
first row: water (gas, liq.)
second row: brine (gas, liq.)
third row: rn1 (gas, liq.)
fourth row: rn2 (gas, liq.)
fifth row: air (gas, liq.)
DIFFU---1-----2-----3-----4-----5-----6-----7-----8
        -1.e-6      -1.e-6
        -1.e-6      -1.e-6
        -1.e-6      -1.e-6
        -1.e-6      -1.e-6
        -1.e-6      -1.e-6

```

Figure 1. TOUGH3 input file for problem 1.

```

ELEME---1---*---2---*---3---*---4---*---5---*---6---*---7---*---8
A  1  19  1  1  .1
B  1  19  1  1  .1
ina 1      1  1.e50
ina 2      1  1.e50

CONNE---1---*---2---*---3---*---4---*---5---*---6---*---7---*---8
ina 1A  1      1  1.e-9  .05  1.
A  1A  2  18  1  1  1  .05  .05  1.
ina 2B  1      1  1.e-9  .05  1.
B  1B  2  18  1  1  1  .05  .05  1.

INCON---1---*---2---*---3---*---4---*---5---*---6---*---7---*---8
ina 1
      1.E5      1.e-3      1.e-7      1.e-8
      1.e-6      9.0
ina 2
      1.E5      1.e-3      1.e-13      1.e-4
      1.e-5      125.0
B  1  19  1
      1.E5      0.0      0.0      0.0
      0.0      125.0

GENER---1---*---2---*---3---*---4---*---5---*---6---*---7---*---8

OUTPU---1---*---2---*---3---*---4---*---5---*---6---*---7---*---8
  9
PRESSURE
TEMPERATURE
SATURATION      2
MASS FRACTION  2  2
MASS FRACTION  2  3
MASS FRACTION  2  4
MASS FRACTION  1  5
MASS FRACTION  1  3
MASS FRACTION  1  4

ENDCY---1---*---2---*---3---*---4---*---5---*---6---*---7---*---8

```

Figure 1. TOUGH3 input file for problem 1 (continued).

```

...ITERATING... AT [ 1, 1] --- DELTEX = 0.100000E+04 MAX. RES. = 0.249983E-01 AT ELEMENT A0001 EQUATION 6
...ITERATING... AT [ 1, 2] --- DELTEX = 0.100000E+04 MAX. RES. = 0.180084E-06 AT ELEMENT A0001 EQUATION 1
A0001( 1, 3) ST = 0.100000E+04 DT = 0.100000E+04
...ITERATING... AT [ 2, 1] --- DELTEX = 0.200000E+04 MAX. RES. = 0.379744E-01 AT ELEMENT A0001 EQUATION 6
...ITERATING... AT [ 2, 2] --- DELTEX = 0.200000E+04 MAX. RES. = 0.299235E-06 AT ELEMENT A0001 EQUATION 1
A0001( 2, 3) ST = 0.300000E+04 DT = 0.200000E+04
...ITERATING... AT [ 3, 1] --- DELTEX = 0.400000E+04 MAX. RES. = 0.477807E-01 AT ELEMENT A0001 EQUATION 6
...ITERATING... AT [ 3, 2] --- DELTEX = 0.400000E+04 MAX. RES. = 0.355891E-06 AT ELEMENT A0001 EQUATION 2
A0001( 3, 3) ST = 0.700000E+04 DT = 0.400000E+04
...ITERATING... AT [ 4, 1] --- DELTEX = 0.800000E+04 MAX. RES. = 0.469317E-01 AT ELEMENT A0001 EQUATION 6
...ITERATING... AT [ 4, 2] --- DELTEX = 0.800000E+04 MAX. RES. = 0.344583E-06 AT ELEMENT A0001 EQUATION 2
A0002( 4, 3) ST = 0.150000E+05 DT = 0.800000E+04
...ITERATING... AT [ 5, 1] --- DELTEX = 0.160000E+05 MAX. RES. = 0.375411E-01 AT ELEMENT A0002 EQUATION 6
...ITERATING... AT [ 5, 2] --- DELTEX = 0.160000E+05 MAX. RES. = 0.205188E-06 AT ELEMENT A0002 EQUATION 1
A0002( 5, 3) ST = 0.310000E+05 DT = 0.160000E+05
...ITERATING... AT [ 6, 1] --- DELTEX = 0.320000E+05 MAX. RES. = 0.389930E-01 AT ELEMENT A0002 EQUATION 6
...ITERATING... AT [ 6, 2] --- DELTEX = 0.320000E+05 MAX. RES. = 0.191810E-06 AT ELEMENT A0003 EQUATION 1
A0003( 6, 3) ST = 0.630000E+05 DT = 0.320000E+05
...ITERATING... AT [ 7, 1] --- DELTEX = 0.640000E+05 MAX. RES. = 0.378766E-01 AT ELEMENT A0003 EQUATION 6
...ITERATING... AT [ 7, 2] --- DELTEX = 0.640000E+05 MAX. RES. = 0.185065E-06 AT ELEMENT A0004 EQUATION 1
A0004( 7, 3) ST = 0.127000E+06 DT = 0.640000E+05
...ITERATING... AT [ 8, 1] --- DELTEX = 0.100000E+06 MAX. RES. = 0.290463E-01 AT ELEMENT A0004 EQUATION 6
...ITERATING... AT [ 8, 2] --- DELTEX = 0.100000E+06 MAX. RES. = 0.132331E-06 AT ELEMENT A0005 EQUATION 1
A0003( 8, 3) ST = 0.227000E+06 DT = 0.100000E+06
...ITERATING... AT [ 9, 1] --- DELTEX = 0.100000E+06 MAX. RES. = 0.157680E-01 AT ELEMENT A0006 EQUATION 6
...ITERATING... AT [ 9, 2] --- DELTEX = 0.100000E+06 MAX. RES. = 0.596077E-07 AT ELEMENT A0007 EQUATION 1
A0005( 9, 3) ST = 0.327000E+06 DT = 0.100000E+06
.....
.....
*rdif* ... simple diffusion problem for EOS7R

                OUTPUT DATA AFTER ( 20, 2)-2-TIME STEPS                                THE TIME IS 0.165162E+02 DAYS
O#####

TOTAL TIME      KCYC   ITER  ITERC   KON      DX1M      DX2M      DX3M      MAX. RES.      NER      KER      DELTEX
0.142700E+07    20     2     58     2     0.31203E+03 0.32959E-04 0.32959E-08 0.82085E-08    20     1     0.10000E+06
O#####

ELEM.  INDEX  PRES      TEMP      SAT_L      X_BRINE_L  X_Rn1_L  X_Rn2_L  X_AIR_G  X_Rn1_G  X_Rn2_G
(PA)    (DEC-C)  (-)      (-)      (-)      (-)      (-)      (-)      (-)      (-)      (-)

A0001   1  0.90821E+05  0.8979E+01  0.1000E+01  0.9786E-03  0.9786E-07  0.9786E-08  0.8873E+00  0.8867E-16  0.8867E-02
A0002   2  0.91192E+05  0.8936E+01  0.1000E+01  0.9361E-03  0.9361E-07  0.9361E-08  0.8834E+00  0.8828E-16  0.8828E-02
A0003   3  0.91562E+05  0.8894E+01  0.1000E+01  0.8939E-03  0.8939E-07  0.8939E-08  0.8792E+00  0.8787E-16  0.8787E-02
A0004   4  0.91929E+05  0.8852E+01  0.1000E+01  0.8524E-03  0.8524E-07  0.8524E-08  0.8747E+00  0.8742E-16  0.8742E-02
A0005   5  0.92289E+05  0.8812E+01  0.1000E+01  0.8119E-03  0.8119E-07  0.8119E-08  0.8699E+00  0.8695E-16  0.8695E-02
A0006   6  0.92641E+05  0.8773E+01  0.1000E+01  0.7725E-03  0.7725E-07  0.7725E-08  0.8649E+00  0.8644E-16  0.8644E-02
A0007   7  0.92983E+05  0.8735E+01  0.1000E+01  0.7346E-03  0.7346E-07  0.7346E-08  0.8595E+00  0.8591E-16  0.8591E-02
A0008   8  0.93311E+05  0.8698E+01  0.1000E+01  0.6984E-03  0.6984E-07  0.6984E-08  0.8540E+00  0.8536E-16  0.8536E-02
A0009   9  0.93624E+05  0.8664E+01  0.1000E+01  0.6640E-03  0.6640E-07  0.6640E-08  0.8482E+00  0.8479E-16  0.8479E-02
A0010  10  0.93919E+05  0.8632E+01  0.1000E+01  0.6318E-03  0.6318E-07  0.6318E-08  0.8424E+00  0.8420E-16  0.8420E-02
.....
.....
B0001  21  0.99991E+05  0.1250E+03  0.0000E+00  0.9786E-03  0.9889E-03  0.9889E-09  0.9786E-05  0.9786E-13  0.9786E-04
B0002  22  0.99991E+05  0.1250E+03  0.0000E+00  0.9361E-03  0.9460E-03  0.9460E-09  0.9361E-05  0.9361E-13  0.9361E-04
B0003  23  0.99992E+05  0.1250E+03  0.0000E+00  0.8939E-03  0.9034E-03  0.9034E-09  0.8939E-05  0.8939E-13  0.8939E-04
B0004  24  0.99992E+05  0.1250E+03  0.0000E+00  0.8524E-03  0.8615E-03  0.8615E-09  0.8524E-05  0.8524E-13  0.8524E-04
B0005  25  0.99992E+05  0.1250E+03  0.0000E+00  0.8119E-03  0.8206E-03  0.8206E-09  0.8119E-05  0.8119E-13  0.8119E-04
B0006  26  0.99993E+05  0.1250E+03  0.0000E+00  0.7725E-03  0.7808E-03  0.7808E-09  0.7725E-05  0.7725E-13  0.7725E-04
B0007  27  0.99993E+05  0.1250E+03  0.0000E+00  0.7346E-03  0.7425E-03  0.7425E-09  0.7346E-05  0.7346E-13  0.7346E-04
B0008  28  0.99993E+05  0.1250E+03  0.0000E+00  0.6984E-03  0.7059E-03  0.7059E-09  0.6984E-05  0.6984E-13  0.6984E-04
B0009  29  0.99994E+05  0.1250E+03  0.0000E+00  0.6640E-03  0.6712E-03  0.6712E-09  0.6640E-05  0.6640E-13  0.6640E-04
B0010  30  0.99994E+05  0.1250E+03  0.0000E+00  0.6318E-03  0.6386E-03  0.6386E-09  0.6318E-05  0.6318E-13  0.6318E-04
.....
.....
ina01  41  0.10000E+06  0.9000E+01  0.1000E+01  0.1000E-02  0.1000E-06  0.1000E-07  0.8891E+00  0.8885E-16  0.8885E-02
ina02  42  0.10000E+06  0.1250E+03  0.0000E+00  0.1000E-02  0.1011E-02  0.1011E-08  0.1000E-04  0.1000E-12  0.1000E-03

```

Figure 2. Selected output for problem 1.

The input file shown in Figure 1 is slightly modified from the original input file included in the TOUGH2 user's guide (Pruess et al., 2012). Data block **OUTPU** is used to select printout variables, and the material and volume information for blocks "ina 1" and "ina 2" are added. TOUGH3 no longer supports using an element with a zero or negative volume to indicate the element and all subsequent elements to be used for Dirichlet boundary conditions. If a zero or negative volume is read, the code will internally assign a very large volume only for that element and print out a warning message as shown in Figure 3. If no material information is provided, an error message will be printed out (see Figure 3), and the simulation will stop running.

```
***** WARNING *****
ELEMENT ina01 HAS A ZERO OR NEGATIVE VOLUME.
TOUGH3 NO LONGER SUPPORTS INACTIVE ELEMENTS.
AN ARBITRARY LARGE VOLUME IS ASSIGNED INSTEAD.
*****

***** WARNING *****
ELEMENT ina02 HAS A ZERO OR NEGATIVE VOLUME.
TOUGH3 NO LONGER SUPPORTS INACTIVE ELEMENTS.
AN ARBITRARY LARGE VOLUME IS ASSIGNED INSTEAD.
*****

***** ERROR *****
* Material ' 0' not found in TOUGH input file, block ROCKS.1!
***** ERROR *****
```

Figure 3. Error messages if the TOUGH2 input formats are used for blocks "ina 1" and "ina 2" as inactive boundary blocks.

3.2. Problem No. 2 (*rdica*) - Contamination of an Aquifer from VOC Vapors in the Vadose Zone

This problem uses EOS7R to simulate the diffusive and advective spreading of volatile organic contaminants (VOCs) in the vadose zone, and their migration across the capillary fringe region into an underlying aquifer. Our emphasis is on approach and data preparation for this kind of analysis, and a very simple model system as shown in Figure 4 is used.

A one-dimensional vertical column of 15 m height and 1 m² cross-sectional area is divided into 15 grid blocks of 1 m thickness each; see the MESHMaker data in the input file, Figure 5. The problem is run in several segments. We first perform a mesh generation run, and then edit the MESH file to change the volume of grid block “AB1 1” at a depth of -10.5 m to a very large number, and add grid blocks “top ” and “bot ” that will later serve to maintain boundary conditions at the land surface, and at the bottom of the water table. A first flow simulation is performed with EOS7 for a clean system (no VOC), to obtain a gravity-capillary equilibrium relative to the gas and capillary pressure conditions specified in block “AB1 1”. (EOS7R with mass fractions specified as $X_{Rn1} = X_{Rn2} = 0$ could also be used.) Data block **MULTI** and initial condition specifications for EOS7, using pure water (zero brine mass fraction), are shown in Figure 5.

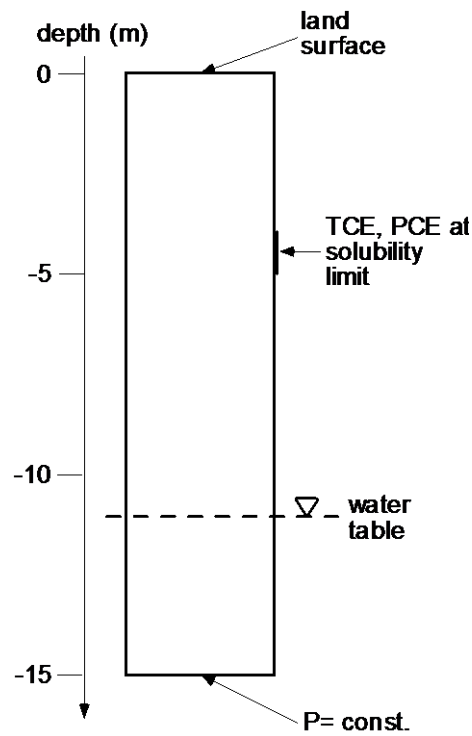

Figure 4. Model system for examining migration of VOC from the vadose zone into an aquifer.

```

MESHMAKER1-----*-----2-----*-----3-----*-----4-----*-----5-----*-----6-----*-----7-----* -
XYZ
      00.
NX      1      1.0
NY      1      1.0
NZ      15     1.0

ENDFI-----1-----*-----2-----*-----3-----*-----4-----*-----5-----*-----6-----*-----7-----* -
MULTI-----1-----*-----2-----*-----3-----*-----4-----*-----5-----*-----6-----*-----7-----* -
      3      3      2      6
INDOM-----1-----*-----2-----*-----3-----*-----4-----*-----5-----*-----6-----*-----7-----* -
vados
      1.013e5      0.      10.50
aquif
      1.5e5      0.      1.e-12
atmos
      1.013e5      0.      .99

INCON-----1-----*-----2-----*-----3-----*-----4-----*-----5-----*-----6-----*-----7-----* -
AB1 1
      1.013e5      0.      10.20

```

Figure 5. Part of TOUGH3 input data for mesh generation and for initializing an EOS7 run to obtain gravity-capillary equilibrium.

The thermodynamic conditions obtained in this run are then used to initialize an EOS7R run, using parameters of $(NK, NEQ, NPH, NB, NKIN) = (5, 5, 2, 8, 3)$ in data block **MULTI**. A single small time step of $\Delta t = 1.e-9$ s is performed, in order to translate the gravity-capillary equilibrium conditions into EOS7R-format. These conditions are used in a subsequent EOS7R run to study migration of TCE and PCE. The VOC data needed for this (aqueous solubilities, inverse Henry's constants) are conveniently obtained with brief T2VOC runs, and are listed in Table 2. The abbreviated TOUGH3 input file for the problem is shown in Figure 6.

Table 2. TCE and PCE data for VOC contamination problem.

VOC	TCE	PCE
molecular weight	131.389	165.834
aqueous phase mass fraction, ppm	1099.84	200.628
vapor pressure at $T = 20$ °C, Pa	7196	1845
inverse Henry's constant, Pa ⁻¹	2.0996e-8	1.1816e-8

```

*rdica* ... diffusion in a 1-D column across a capillary fringe
ROCKS----1----*----2----*----3----*----4----*----5----*----6----*----7----*----8
vados    2  2600.e00      .35   1.e-11  1.0e-11  1.e-11    2.51    920.
          0.25
          7      .457      .15      1.      .10
          7      .457      .00  5.105e-4  1.e7      1.
.....
.....

MULTI----1----*----2----*----3----*----4----*----5----*----6----*----7----*----8
5 5 2 8
START----1----*----2----*----3----*----4----*----5----*----6----*----7----*----8
----*----1 MOP: 123456789*123456789*1234 ----*----5----*----6----*----7----*----8
SOLVR----1----*----2----*----3----*----4----*----5----*----6----*----7----*----8
3 Z1 00 8.0e-1 1.0e-7
PARAM----1----*----2----*----3----*----4----*----5----*----6----*----7----*----8
3 200 999 0 0 0000020000400 00
          3.15576e9 -1. A51 1 9.81
          1. 9. 9.e1 9.e2 9.e3 9.e4 9.e5 9.e6
          1.e-5
          1.013e5 0. 0.
          10.50 20.
TIMES----1----*----2----*----3----*----4----*----5----*----6----*----7----*----8
6
          1. 31.5576e6 157.788e6 315.576e6 946.728e6 3.15576e9
SELEC----1----*----2----*----3----*----4----*----5----*----6----*----7----*----8
6
          -1.e5
          0.e-0 0.e-1
          0.e-6 0.e-6 0.e-6 -1.e-6 -1.e-6 0.e-6
          1.e50 131.389 0.e-6 -1.e-6 2.10e-08
          1.e50 165.834 -1.e-6 0.e-6 1.18e-08
DIFFU----1----*----2----*----3----*----4----*----5----*----6----*----7----*----8
1.e-6 1.e-10
0.e-6 0.e-6
1.e-6 1.e-10
1.e-6 1.e-10
1.e-6 1.e-10
ELEME----1----*----2----*----3----*----4----*----5----*----6----*----7----*----8
A11 1 vados .1000E+01 .1000E+01 .5000E+00 .5000E+00-.5000E+00
.....
.....
AF1 1 aquif .1000E+01 .1000E+01 .5000E+00 .5000E+00-.1450E+02
con 0 trapp .1000E+51
top 0 atmos .1000E+51
bot 0 aquif .1000E+51

CONNE----1----*----2----*----3----*----4----*----5----*----6----*----7----*----8
con 0A51 1 1 1.e-9 .5 1.e-1
top 0A11 1 3 1.e-9 .5 1. 1.
A11 1A21 1 3 .5000E+00 .5000E+00 .1000E+01 .1000E+01
.....
AE1 1AF1 1 3 .5000E+00 .5000E+00 .1000E+01 .1000E+01
AF1 1bot 0 3 .5 1.e-9 1. 1.

.9999999999008E-12 .2000000000000E+02

GENER----1----*----2----*----3----*----4----*----5----*----6----*----7----*----8
ENDCY----1----*----2----*----3----*----4----*----5----*----6----*----7----*----8

```

Figure 6. Abbreviated TOUGH3/EOS7R input data file for VOC migration problem.

```

INCON -- INITIAL CONDITIONS FOR 19 ELEMENTS AT TIME .100000E-08
All 1 .35000000E+00
.1011830232536E+06 .0000000000000E+00 .0000000000000E+00 .0000000000000E+00
.1084703339434E+02 .2000000000000E+02
.....
AF1 1 .35000000E+00
.1389509605809E+06 .0000000000000E+00 .0000000000000E+00 .0000000000000E+00
.9999999996652E-12 .2000000000000E+02
con 0 .35000000E+00
.1012297975914E+06 .0000000000000E+00 1.0998e-3 2.0063e-4
.1084567823274E+02 .2000000000000E+02
top 0 .35000000E+00
.1011771700865E+06 .0000000000000E+00 .0000000000000E+00 .0000000000000E+00
.9899948379529E+00 .2000000000000E+02
bot 0 .35000000E+00
.1438478256741E+06 .0000000000000E+00 .0000000000000E+00 .0000000000000E+00
.9999999999008E-12 .2000000000000E+02

GENER----1----*----2----*----3----*----4----*----5----*----6----*----7----*----8

OUTPU----1----*----2----*----3----*----4----*----5----*----6----*----7----*----8
9
PRESSURE
TEMPERATURE
SATURATION 2
MASS FRACTION 2 2
MASS FRACTION 2 3
MASS FRACTION 2 4
MASS FRACTION 1 5
MASS FRACTION 1 3
MASS FRACTION 1 4

ENDCY----1----*----2----*----3----*----4----*----5----*----6----*----7----*----8

```

Figure 6. Abbreviated TOUGH3/EOS7R input data file for VOC migration problem (continued).

Prior to simulating VOC migration, the mesh is again edited; the volume of “AB1 1” is returned back to the original value, and the volume of the top and bottom boundary blocks are changed to a very large number, to maintain time-independent land surface and aquifer bottom boundary conditions. An additional grid block with a very large volume is added to the mesh to serve as a VOC source. This block, called “con ”, is connected to grid block “A51 1” at -4.5 m depth, and is initialized with conditions identical to “A51 1”, except that components Rn1 and Rn2 were assigned small non-zero mass fractions of 1.0998e-3 and 2.0063e-4, respectively. These correspond to aqueous phase solubilities of TCE and PCE at $T = 20\text{ }^{\circ}\text{C}$, and model a situation where VOC is present as a free but immobile NAPL (non-aqueous phase liquid). Diffusivities for all components are specified as $10^{-6}\text{ m}^2/\text{s}$ in the gas phase, $10^{-10}\text{ m}^2/\text{s}$ in the aqueous phase. The tortuosity factor is 0.25, and relative permeabilities are used as saturation-dependent tortuosity coefficients; no adsorption is included.

Part of the printout generated after $t = 1$ year is shown in Figure 7; results for the time dependence of VOC concentrations in grid block “A1 1” just below the water table are plotted in Figure 8 for two variations of the problem with different handling of multiphase diffusion.

The general behavior observed in the simulation can be summarized as follows. Transfer of TCE and PCE from the source block into the 1-D column occurs virtually exclusively by gas diffusion, because the liquid phase tortuosity factor near irreducible water saturation is very small, while gas phase tortuosity is near 1. After entering the column, the diffusive spreading of VOCs upward and downward from grid block “A51 1” is nearly symmetric initially, as can be seen from the data printed in Figure 7 (radionuclide mass fractions in “A61 1” are close to but slightly larger than those in “A41 1”, etc.). The asymmetry with larger mass fractions below than above the VOC entry point is caused by buoyancy-driven downflow of soil gas, due to the entry of denser VOC vapors into the vadose zone. These advective flow effects become stronger over time as VOC concentrations and soil gas densities increase. The downflow of soil gas is compensated by upward diffusion of air. Due to the relatively small aqueous phase solubilities, and the much smaller liquid as compared to gas phase diffusivities, there is a large resistance for diffusion across the capillary fringe. This delays entry of VOCs into the aquifer until concentrations above the water table have built up to large values. To illustrate the strong coupling between multiphase diffusion and aqueous-gas phase partitioning, we ran two variations for this problem. By setting $MOP(24) = 0$ we obtain an accurate, fully coupled treatment of diffusion and phase partitioning. For $MOP(24) = 1$ diffusive fluxes are calculated separately for the gas and aqueous phases, which can lead to severe underestimate of diffusive fluxes in regions with strong saturation gradients. As is seen in Figure 8, the aqueous phase concentrations beneath the water table are underestimated by as much as an order of magnitude after 100 years for the $MOP(24) = 1$ calculation.

References

de Marsily, G. *Quantitative Hydrogeology*, Academic Press, Orlando, FL, 1986.

Herbert, A.W., C.P. Jackson and D.A. Lever. Coupled Groundwater Flow and Solute Transport with Fluid Density Strongly Dependent on Concentration, *Water Resour. Res.*, Vol. 24, No. 10, pp. 1781 - 1795, 1988.

Oldenburg, C.M. and K. Pruess. EOS7R: Radionuclide Transport for TOUGH2, Lawrence Berkeley Laboratory Report LBL-34868, Berkeley, CA, November 1995.

Pruess, K., C. Oldenburg, and G. Moridis, TOUGH2 User's Guide, Version 2.1, Lawrence Berkeley Laboratory Report LBNL-43134, Berkeley, CA, 2012.

EOS8: An Equation-of-State Module for Water, Air, Oil

Yoojin Jung
George Pau
Stefan Finsterle

Earth Sciences Division, Lawrence Berkeley National Laboratory
University of California, Berkeley, California 94720

1. Description

EOS8 is an enhanced version of EOS3, and is developed from EOS3 by adding a third non-volatile, insoluble component, called "oil," which can only exist in a separate, immiscible phase. This module provides a very basic and simple capability for modeling three fluid phases, including gaseous, aqueous, and oleic phases. EOS8 can represent what in petroleum engineering is often referred to as a "dead oil," meaning a non-aqueous phase liquid that has no volatile or soluble components, so that it is present only in the non-aqueous phase. The thermophysical property description related to the third (oil) phase is intentionally kept very simple and, although EOS8 may be applicable to some flow problems of practical interest as is, it should be considered a development platform rather than a realistic description of three-phase fluid systems.

The relative permeabilities of the gas and aqueous phases are considered functions of their respective phase saturations only, $k_{rg} = k_{rg}(S_g)$, $k_{rl} = k_{rl}(S_{aq})$, and are specified through input data in the usual manner. The oil phase is considered of intermediate wettability, and its relative permeability is described in a schematic fashion that is intended to serve as a template for users.

$$k_{ro} = \frac{S_o - S_{or}}{1 - S_{or}} \quad (1)$$

Here, S_{or} is the residual oil saturation. Oil phase capillary pressure is neglected. Viscosity, density, and specific enthalpy of the oil phase are described as functions of pressure and temperature through low-order polynomials, with user-specified parameters entered through data block **SELEC**. More specifically, viscosity is written as

$$\begin{aligned} \mu_{oil} = & a + b(P - P_1) + c(P - P_2)^2 \\ & + d(T - T_1) + e(T - T_2)^2 \end{aligned} \quad (2)$$

Oil density is

$$\rho_{oil} = \rho_0 + C(P - P_0) - E(T - T_0) \quad (3)$$

where ρ_o is oil density at reference pressure and temperature conditions of (P_o, T_o) . Specific enthalpy of oil is assumed proportional to temperature (normalized to $h_{oil} = 0$ at $T = 0$ °C).

$$h_{oil} = \zeta T \quad (4)$$

All parameters appearing in the oil phase property description in Eqs. 2, 3, and 4 are to be provided by the user through data block **SELEC** (see Section 2 below). The property correlations are implemented through arithmetic statement functions at the top of EOS8 in a manner that should be transparent to users. Users may also refer detailed comment statements in the EOS8 source code for instructions of preparing EOS8 input data.

2. Specifications

A summary of EOS8 specifications and parameters is given in Table 1. The default parameter settings are $(NK, NEQ, NPH, NB) = (3, 3, 3, 6)$. The choice of primary thermodynamic variables is (P, X, S_o, T) for single-phase, $(P_g, S_g + 10, S_o, T)$ for two-phase conditions. With EOS8 the user can optionally run just two phases (aqueous-gas, without the oil phase), in which case the aqueous-gas process descriptions reduce to those of EOS3.

Table 1. Summary of EOS8

<u>Components</u>	# 1: water # 2: air # 3: oil
<u>Parameter choices</u>	
$(NK, NEQ, NPH, NB) =$	(3, 3, 3, 6) water, air, oil, isothermal (default)
	(3, 4, 3, 6) water, air, oil, nonisothermal
	(2, 2, 2, 6) water, air, no oil, isothermal
	(2, 3, 2, 6) water, air, no oil, nonisothermal
<u>Primary Variables</u>	
	two-phase conditions (gas-oil or aqueous-oil)
	(P, X, S_o, T) - (pressure, air mass fraction, oil phase saturation, temperature)
	three-phase conditions (gas-aqueous-oil)
	$(P_g, S_g + 10, S_o, T)$ - (gas phase pressure, gas saturation plus 10, oil phase

saturation, temperature)

The parameters used in the oil phase property description are specified in the TOUGH3 input file by means of a data block **SELEC**, as follows.

SELEC keyword to introduce a data block with oil phase property parameters.

Record **SELEC.1**

Format (16I5)

IE(1)

IE (1) set equal to 6 to read six additional records with data for brine and radionuclides, and for hydrodynamic dispersion.

Record **SELEC.2** leave this line blank.

Record **SELEC.3** leave this line blank.

Record **SELEC.4**

Format (2E10.4)

S_{or}, a

S_{or} irreducible saturation of oil phase

a constant portion in Eq. 2 for oil phase viscosity

Record **SELEC.5**

Format (8E10.4)

b, P₁, c, P₂, d, T₁, e, T₂

coefficients for oil phase viscosity in Eq. 2.

Record **SELEC.6**

Format (5E10.4)

ρ_o, C, P_o, E, T_o

coefficients for oil density in Eq. 3.

Record **SELEC.7**

Format(E10.4)

ζ

coefficients for oil specific enthalpy in Eq. 4.

3. Sample Problem (*rcol8*) - Flushing Oil from a 1-D Column by Water Injection

We consider a 1-D horizontal porous column of 19 m length and 1 m² cross-sectional area, divided into 19 grid blocks of 1 m³ volume each. Initial conditions are uniform, with $P = 10^5$ Pa, $T = 15$ °C, $S_{gas} = 20$ %, $S_{oil} = 50$ %. These conditions are maintained constant at one end of the column, while water is injected at a rate of 0.03 kg/s and an enthalpy of 2×10^5 J/kg, corresponding to a temperature of approximately 48 °C, at the other end. The input file for this problem is shown in Figure 1. Oil phase specifications include an irreducible saturation $S_{or} = 0.01$, constant viscosity of 0.5×10^{-3} Pa-s, constant density of 800 kg/m³, and specific heat of 1000 J/kg°C.

In response to water injection, pressures increase near the injection point, and three-phase flow of gas, aqueous, and oil phases is induced. Air also partially dissolves in the aqueous phase. Figure 2 shows a portion of the printout, including the iteration sequence during the first few time steps, and results obtained after 10 time steps. At this point, corresponding to a simulated time of 15,900 seconds (4.4 hours), the air that was originally present in the first grid block has been completely removed, mostly through dissolution in the flowing water, with a minor contribution from gas flow at early time. Oil saturations near the inlet have declined, and an oil bank has formed with a broad saturation distribution that peaks at $S_{oil} = 67.9$ % in grid block “F 5”. In reality, oil relative permeability will depend on saturation through $(S_o - S_{or})$ raised to some power larger than 1, and a rather sharp displacement front will develop.

```

*rcol8* ..... input file for EOS8; flushing oil from 1-D column.
ROCKS----1----*----2----*----3----*----4----*----5----*----6----*----7----*----8
SAND          2650.      .30  100.E-15                      2.10      1000.

      Data block 'MULTI' to specify number of fluid components etc.
MULTI----1----*----2----*----3----*----4----*----5----*----6----*----7----*----8
  3      4      3      6
SELEC----1----*----2----*----3----*----4----*----5----*----6----*----7----*----8
  6

      .01      0.5e-3

      0.8e3
      1.e3
START----1----*----2----*----3----*----4----*----5----*----6----*----7----*----8
----*----1 MOP: 123456789*123456789*1234 ----*----5----*----6----*----7----*----8
SOLVR----1----*----2----*----3----*----4----*----5----*----6----*----7----*----8
7 Z1  00      8.0e-1      1.0e-7
PARAM----1----*----2----*----3----*----4----*----5----*----6----*----7----*----8
  2  20          5100000 000000004700
          2.0e4      -1.          F  1
      1.e2

          1.E5          10.20          .50          15.
RPCAP----1----*----2----*----3----*----4----*----5----*----6----*----7----*----8
  3          .20          .10
  7          0.44380      8.01E-2  5.792e-05      5.E6      1.
GENER----1----*----2----*----3----*----4----*----5----*----6----*----7----*----8
F  lwtr 1          COM1          .03      2.e5

ELEME----1----*----2----*----3----*----4----*----5----*----6----*----7----*----8
F  1  18      1SAND 0.1000E+01
F  20          SAND 0.0000E+00

CONNE----1----*----2----*----3----*----4----*----5----*----6----*----7----*----8
F  1F  2  17      1      1      10.5000E+000.5000E+000.1000E+01
F  19F 20          10.5000E+000.0000E+000.1000E+01

INCON----1----*----2----*----3----*----4----*----5----*----6----*----7----*----8

OUTPU----1----*----2----*----3----*----4----*----5----*----6----*----7----*----8
  7
PRESSURE
TEMPERATURE
SATURATION
MASS FRACTION          1      2
MASS FRACTION          2      2
PSAT
CAPILLARY

ENDCY----1----*----2----*----3----*----4----*----5----*----6----*----7----*----8

```

Figure 1. Input file for flushing oil from a 1-D column.

EOS9: An Equation-of-State Module for Variably-Saturated Isothermal flow according to Richards' Equation

Yoojin Jung
George Pau
Stefan Finsterle

Earth Sciences Division, Lawrence Berkeley National Laboratory
University of California, Berkeley, California 94720

1. Description

This module considers variably saturated flow of a single aqueous phase, which consists entirely of a single water component, and neglects phase change effects. The gas phase is treated as a passive bystander at constant pressure, and conditions are assumed to be isothermal. Thus, no mass balance equation for gas and no heat balance is needed, and only a single water mass balance equation is solved for each grid block. This is very efficient numerically, making EOS9 the module of choice for problems for which the underlying approximations are applicable.

Liquid flow in EOS9 is described as follows:

$$\frac{\partial}{\partial t} \phi S_l \rho_l = \text{div} \left[k \frac{k_{rl}}{\mu_l} \rho_l \nabla (P_l + \rho_l g z) \right] \quad (1)$$

where ϕ is porosity, S_l is water saturation, ρ_l is water density, k is absolute permeability, k_{rl} is relative permeability to the aqueous phase, μ_l is water viscosity, P_l is water pressure, g is acceleration of gravity, and z is defined positive upward. Neglecting variations in liquid phase density and viscosity, as is appropriate for (nearly) isothermal conditions, Eq. 1 simplifies to Richards' equation (1931)

$$\frac{\partial}{\partial t} \theta = \text{div} [K \nabla h] \quad (2)$$

where $\theta = \phi S_l$ is specific volumetric moisture content, $K = k k_{rl} \rho_l g / \mu_l$ is hydraulic conductivity, and $h = z + P_l / \rho_l g$ is the hydraulic head. EOS9 can describe flow under partially saturated ($0 < S_l < 1$) as well as fully saturated conditions, and phase changes between the two.

2. Specifications

With only a single mass balance equation per grid block, there is only a single primary thermodynamic variable. This is taken to be pressure for single-phase (saturated) conditions, and is water saturation for unsaturated conditions. A distinction between the two is made simply on the basis of the numerical value of the first (and only) primary variable, XI . If $XI < 1$, this indicates that XI represents water saturation and conditions are unsaturated; if XI is larger than a

user-specified gas phase reference pressure (default $P_{gas} = 1.013 \times 10^5$ Pa), it is taken to be water pressure, and saturated conditions prevail. When phase changes between saturated and unsaturated conditions occur, the primary variable is switched, as follows. The numerical value of XI and its change during the Newton-Raphson iteration process is monitored. If XI changes from being smaller than 1 to larger than 1, this indicates attainment of fully saturated conditions. In that case XI is switched to pressure, and is initialized at a pressure slightly in excess of gas phase reference pressure as $XI = P_{gas}(1 + \varepsilon)$, with $\varepsilon = 10^{-6}$. If XI changes from being larger than P_{gas} to smaller than P_{gas} , this indicates a transition from fully to partially saturated conditions. XI is then switched to saturation, and is initialized as $XI = 1 - \varepsilon$. Actually, a transition from fully to partially saturated conditions is made only when XI drops below $P_{gas}(1 - \varepsilon)$; test calculations have shown that such a (small) finite-size window for phase change improves numerical stability and efficiency.

In EOS9, the thermophysical properties of water are taken at default reference conditions of $P = 1.013 \times 10^5$ Pa, $T = 15$ °C. These defaults can be overwritten in a flexible manner by specifying appropriate data in a fictitious **ROCKS** domain ‘REFCO’, as follows.

```
reference pressure:      DROK of REFCO
reference temperature:  POR of REFCO
liquid density:         PER(1) of REFCO
liquid viscosity:      PER(2) of REFCO
liquid compressibility: PER(3) of REFCO
```

Note that assignment of thermophysical data through a specially-named domain was set up just as a convenient way of providing floating-point parameters to the code. No volume elements (grid blocks) should be attached to domain ‘REFCO’, as the data in general will not correspond to reasonable hydrogeologic parameters. The above mentioned defaults will be overwritten for any parameters for which a non-zero entry is provided in ‘REFCO’. This allows the generation of these parameters internally for user-defined (P , T); it also allows for directly assigning user-desired values as, e.g., $\rho_{liq} = 1000$ kg/m³, $\mu_{liq} = 10^{-3}$ P_a-s (\equiv 1 centipoise), etc. A summary of EOS9 specifications appears in Table 1.

Table 10. Summary of EOS9

<u>Components</u>	# 1: water
<u>Parameter choices</u>	
$(NK, NEQ, NPH, NB) =$	(1, 1, 1, 6) water, isothermal (default; no other choices available)
<u>Primary Variables</u> *†	
saturated conditions	
	$(P_{liq}) - (\text{water pressure: } P_{liq} \geq P_{gas})$
unsaturated conditions	
	$(S_{liq}) - (\text{water saturation: } 0 < S_{liq} < 1)$

* The first primary variable may be initialized as $XI < 0$, in which case it will be taken to denote capillary pressure, and will be converted internally to S_{liq} in the initialization phase.

† Reference gas phase pressure, flow system temperature, and (optionally) thermophysical parameters of water density, viscosity, and compressibility may be specified through a fictitious **ROCKS** domain 'REFCO'.

In addition to specifying the primary thermodynamic variable on a default, domain, or grid block basis, EOS9 offers alternative ways of initializing flow problems. The primary variable may be entered as a negative number upon initialization, in which case it will be taken to denote capillary pressure, and will be internally converted to S_l in the initialization phase. EOS9 can also initialize a flow problem with gravity-capillary equilibrium, relative to a user-specified reference elevation z_{ref} of the water table. This type of initialization will be engaged if the user enters a non-zero number in slot $CWET$ in **ROCKS** domain 'REFCO', in which case $CWET$ will be taken to denote the water table elevation z_{ref} , in units of meters. Water pressure at z_{ref} is taken equal to reference gas pressure, $P_l(z_{ref}) = P_{gas}$, and is initialized as a function of grid block elevation according to $P(z) = P_{gas} + (z_{ref} - z)\rho g$. By convention, the z-axis is assumed to point upward. In order to use this facility, the z-coordinates (grid block elevations) must be specified in the **ELEME**-data, which will be done automatically if internal MESH generation is used.

In the assignment of gravity-capillary equilibrium as just discussed, water saturations at “sufficiently” high elevations above the water table may end up being smaller than the irreducible water saturation S_{lr} specified in the relative permeability function, which may or may not be consistent with the physical behavior of the flow system. Users may optionally enforce that $S_l = S_{lr}$ in regions where the capillary pressure function would dictate that $S_l < S_{lr}$. This is

accomplished by entering an appropriate parameter in slot $SPHT$ of **ROCKS** domain 'REFCO', and works as follows. The irreducible saturation S_{lr} will be taken to be parameter $RP(\text{int}(SPHT))$ of the relative permeability function. As an example, for the $IRP = 7$ relative permeability function, irreducible water saturation is the parameter $RP(2)$; therefore, for $IRP = 7$ the user should specify $SPHT = 2.0$ in 'REFCO' to use this facility.

EOS9 differs from all of the other EOS modules in that, having only a single primary thermodynamic variable, the first (and here only) primary variable does not necessarily denote pressure. This necessitates certain other coding adjustments. For EOS9, the flow terms is assembled differently in subroutine MULTI, and the slot # 6 of the PAR -array, which normally holds just the capillary pressure, represents total water pressure $P_l = P_{gas} + P_{cap}$.

3. Sample Problems

3.1. Problem No. 1 (*reos9a*) - Demonstration of Equilibrium

This problem demonstrates initialization of a flow problem with gravity-capillary equilibrium. MESHMaker is used to generate a vertical 1-D column consisting of 10 grid blocks with 10 m height and 1 m² cross-sectional area. Nodal point elevations range from -5 m at the top (block A11 1) to -95 m at the bottom (block AA1 1). In domain REFCO a water table elevation of -75 m is specified, corresponding to the center of grid block A81 1. Other problem specifications can be read from the input file, Figure 1.

Some of the printed output is shown in Figure 2. The printout after the first infinitesimal time step of $\Delta t = 1.e-9$ s shows the initialization made by EOS9, with unsaturated conditions above block A81 1 and saturated conditions below. Mass fluxes obviously vanish in the region above grid block A61 1, because water saturations are below the irreducible value of $S_{liq} = 0.15$ there. Very small water flow velocities of order 10^{-20} m/s are present in the mobile portion of the unsaturated zone, while considerably larger albeit still small flow velocities of order 10^{-10} m/s (approximately 3 mm/yr) are seen between the saturated zone blocks. The reason for gravity-capillary equilibrium being slightly less accurate in the saturated zone is that water density will slightly increase with increasing pressure, which is neglected in the assignment of pressure conditions in EOS9. A time step of 10^9 seconds is then performed for which convergence is obtained after a single Newton-Raphson iteration. The maximum pressure change in any grid block is 8.7 Pa, and a more accurate gravity-capillary equilibrium is obtained, with saturated zone flow velocities reduced by another six orders of magnitude.

The input file includes alternative REFCO specifications after the **ENDCY** record. If these are used, all unsaturated zone grid blocks will be initialized at irreducible water saturation of 15%.

3.2.Problem No. 2 (*rpm*) - Demonstration of Permeability Modification Options

Here we present a small, coarsely gridded problem to illustrate the various block-by-block permeability modification options. The TOUGH3 input file is shown in Figure 3, and applies internally generated “logarithmic” random permeability modifiers (Option 3). Figure 4 shows the MESHMaker data that were used to generate the grid, and provides alternative data for domain SEED that can be used instead of the SEED data in Figure 3 to select linear random permeability modifiers (Option 2), or user-supplied permeability modifiers in data block **ELEME** (Option 1).

In assembling the input file of Figure 3, we first performed a MESH generation run, and then added arbitrary PM-coefficients to the **ELEME**-data using a text editor. Reference hydrogeologic conditions feature typical parameters for a coarse sand, with permeability of 10^{-11} m² (10 darcy). Default initial water saturation is 14.99 %, just below the irreducible level of 15 %, and the top three grid blocks are initialized at a large water saturation of 99 % (A11 1, A11 2, A11 3; note that the y-axis of the grid has been rotated by 90 ° about the x-axis, so that it is pointing downward).

In the input file as shown in Figure 3, the explicitly provided PM-coefficients will not be used; instead the domain SEED data will cause a set $\{s_n; n = 1, \dots, NEL\}$ of random numbers in the interval [0, 1] to be internally generated, with a random number seed of 0.5 (*POR*-parameter in domain SEED). The permeability modifiers will be calculated as (logarithmic permeability modification)

$$\zeta_n = \max\{\exp(-\sigma \cdot s_n) - \Delta, 0\} \quad (43).$$

where $\sigma \equiv PER(1) = 6.909$ is a scale factor, which will cause permeability modifiers to cover the range from $\exp(-6.909) \approx 10^{-3}$ to $\exp(0) \equiv 1$, and $\Delta \equiv PER(2) = 0.01$ is a shift parameter. The input data in Figure 3 require a first small time step of $\Delta t = 10^{-9}$ s, after which the initial conditions are printed prior to any changes. Figure 5 shows part of the iteration sequence starting from time step # 2, and the output data after 10 time steps, corresponding to a simulated time of 2.56×10^5 seconds. Basically what is happening in the problem is that water is flowing downward under gravity, in a manner that is affected by capillary pressure variations. Grid block A12 1 is impermeable, so that outflow from block A11 1 above it can only occur sideways, by capillary force, into block A11 2.

```

MESHMAKER1-----*-----2-----*-----3-----*-----4-----*-----5-----*-----6-----*-----7-----*-----8
XYZ
      90.
NX      3      1.0
NY      3      1.0
NZ      1      1.0

ENDFI----1----*----2----*----3----*----4----*----5----*----6----*----7----*----8
#####
.....data for using permeability modifiers supplied in ELEME data block
      shift = 1.5
SEED                                  1.5
.....data for intrinsic generation of permeability modifiers
      use random numbers with seed = 0.8
....."linear" per. mod.; scale factor 4.0 (i.e., per. mod. between 0 and 4);
      shift = 1.2
SEED      0.8      4.0      1.2
.....data for intrinsic generation of permeability modifiers
      use random numbers with seed = 0.5
....."logarithmic" per. mod.; scale factor 6.909 (i.e., per. mod. between
      10^0 and 10^-3); shift = 0.01
SEED      .5      6.909      0.01

```

Figure 4. MESHMaker input, alternative SEED data.

As a benchmark we also provide portions of the printout from EOS9 runs that use internally generated random linear permeability modifiers with a shift of $\Delta = 1.2$ (Figure 6), and the explicitly provided permeability modifiers in the **ELEME**-block with a shift of $\Delta = 1.5$ (Figure 7). These permeability fields are very different from the previous case and, accordingly, rather different saturation distributions are obtained.

References

Richards, L.A. Capillary Conduction of Liquids Through Porous Mediums, *Physics*, Vol. 1, pp. 318 - 333, 1931.

EWASG: An Equation-of-State Module for Water, NaCl, Non-Condensable Gas

Yoojin Jung
George Pau
Stefan Finsterle

Earth Sciences Division, Lawrence Berkeley National Laboratory
University of California, Berkeley, California 94720

1. Description

1.1. Thermophysical Properties

The EWASG (WATER-SALT-GAS) fluid property module was developed by Battistelli et al. (1997) for modeling geothermal reservoirs with saline fluids and non-condensable gas (NCG). In contrast to EOS7, EWASG describes aqueous fluid of variable salinity not as a mixture of water and brine, but as a mixture of water and NaCl. This makes it possible to represent temperature-dependent solubility constraints, and to properly describe precipitation and dissolution of salt. EWASG represents the active system components (water, NaCl, NCG) as three-phase mixtures. Solid salt is the only active mineral phase, and is treated in complete analogy to fluid phases (aqueous, gas), except that, being immobile, its relative permeability is identically zero. From mass balances on salt in fluid and solid phases we calculate the volume fraction of precipitated salt in the original pore space ϕ_0 , which is termed “solid saturation,” and denoted by S_s . A fraction $\phi_0 S_s$ of reservoir volume is occupied by precipitate, while the remaining void space $\phi_f = \phi_0(1 - S_s)$ is available for fluid phases. We refer to ϕ_f as the “active flow porosity.” The reduction in pore space reduces the permeability of the medium (see Section 1.2).

Several choices are available for the non-condensable gas (NCG): CO₂, air, CH₄, H₂, and N₂. Gas dissolution in the aqueous phase is described by Henry’s law, with coefficients that depend not only on temperature but also on salinity to describe the reduction in NCG solubility with increasing salinity (“salting out”). The dependence of brine density, enthalpy, viscosity, and vapor pressure on salinity is taken into account, as are vapor pressure-lowering effects from suction pressures (capillary and vapor adsorption effects). The thermophysical property correlations used in EWASG are accurate for most conditions of interest in geothermal reservoir studies: temperatures in the range from 100 to 350 °C, fluid pressures up to 80 MPa, CO₂ partial pressures up to 10 MPa, and salt mass fraction up to halite saturation. With the exception of brine enthalpy, thermophysical property correlations are accurate to below 10 °C. A full discussion of the thermophysical property correlations used and their empirical basis is given in the original paper (Battistelli et al., 1997).

TOUGH3 also adopts recent improvements of EWASG. Internally consistent correlations for the water-NaCl mixture properties are included (Battistelli, 2012), which are developed by Driesner and Heinrich (2007) and Driesner (2007). These brine correlations are capable to calculate phase properties for temperatures from 0 to 350 °C, pressures from 1 to 100 MPa, and

salt mass fraction up to saturation. In TOUGH3, the brine correlations in Driesner (2007) are used as the default, unless specified differently by users.

New options are also added to calculate NCG (CO₂, CH₄, and H₂ only) density and fugacity using a virial equation treatment of Spycher and Reed (1988). This method is available and reliable only for the following temperature and pressure ranges: 1) for CO₂, 50 – 350 °C and up to 50 MPa, 2) for CH₄, 16 – 350 °C and up to 50 MPa, and 3) for H₂, 25 – 600 °C and up to 300 MPa.

1.2. Permeability Change

As noted above, the relationship between the amount of solid precipitation and the pore space available to the fluid phases is very simple. The impact of porosity change on formation permeability on the other hand is highly complex. Laboratory experiments have shown that modest reductions in porosity from chemical precipitation can cause large reductions in permeability (Vaughan, 1987). This is explained by the convergent-divergent nature of natural pore channels, where pore throats can become clogged by precipitation while disconnected void spaces remain in the pore bodies (Verma and Pruess, 1988). The permeability reduction effects depend not only on the overall reduction of porosity but on details of the pore space geometry and the distribution of precipitate within the pore space. These may be quite different for different porous media, which makes it difficult to achieve generally applicable, reliable predictions. EWASG offers several choices for the functional dependence of relative change in permeability, k/k_0 , on relative change in active flow porosity.

$$\frac{k}{k_0} = f\left(\frac{\phi_f}{\phi_0}\right) \equiv f(1-S_s) \quad (1)$$

The simplest model that can capture the converging-diverging nature of natural pore channels consists of alternating segments of capillary tubes with larger and smaller radii, respectively; see Figure 1. While in straight capillary tube models permeability remains finite as long as porosity is non-zero, in models of tubes with different radii in series, permeability is reduced to zero at a finite porosity.

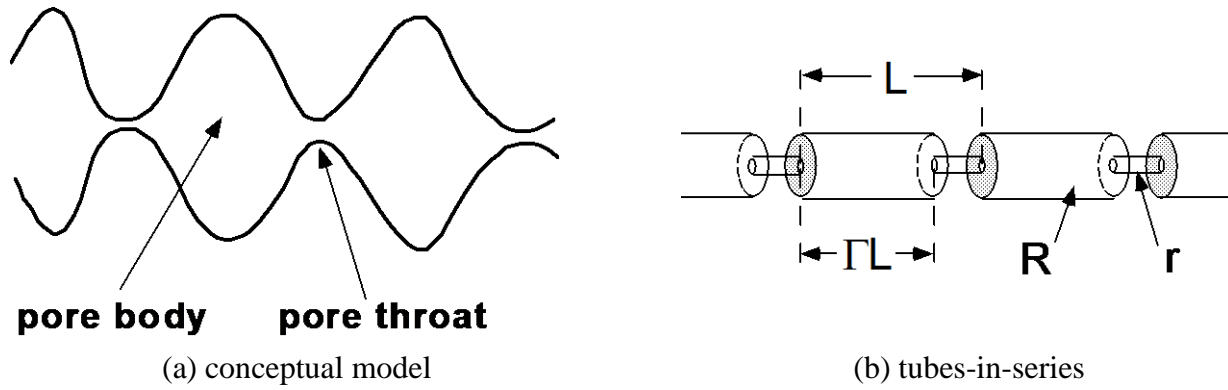

Figure 1. Model for converging-diverging pore channels.

From the tubes-in-series model shown in Figure 1, the following relationship can be derived (Verma and Pruess, 1988)

$$\frac{k}{k_0} = \theta^2 \frac{1 - \Gamma + \Gamma/\omega^2}{1 - \Gamma + \Gamma[\theta/(\theta + \omega - 1)]^2} \quad (2)$$

Here

$$\theta = \frac{1 - S_s - \phi_r}{1 - \phi_r} \quad (3)$$

depends on the fraction $1 - S_s$ of original pore space that remains available to fluids, and on a parameter ϕ_r , which denotes the fraction of original porosity at which permeability is reduced to zero. Γ is the fractional length of the pore bodies, and the parameter ω is given by

$$\omega = 1 + \frac{1/\Gamma}{1/\phi_r - 1} \quad (4)$$

Therefore, Eq. (2) has only two independent geometric parameters that need to be specified, ϕ_r and Γ . As an example, Figure 2 shows the permeability reduction factor from Eq. (2), plotted against $\phi/\phi_0 \equiv (1 - S_s)$, for parameters of $\phi_r = \Gamma = 0.8$.

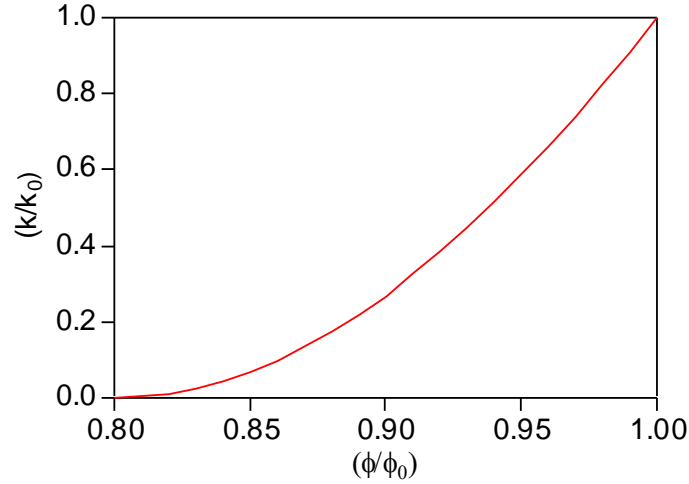

Figure 2. Porosity-permeability relationship for tubes-in-series model, after Verma and Pruess (1988).

For parallel-plate fracture segments of different aperture in series, a relationship similar to Eq. (2) is obtained, the only difference being that the exponent 2 is replaced everywhere by 3 (Verma and Pruess, 1988). If only straight capillary tubes of uniform radius are considered, we have $\phi_r = 0$, $\Gamma = 0$, and Eq. (2) simplifies to

$$k/k_0 = (1 - S_s)^2 \quad (5)$$

2. Specifications

A summary of EWASG specifications and parameters appears in Table 1. The default parameter settings are $(NK, NEQ, NPH, NB) = (3, 4, 3, 6)$. The $NK = 2$ (no air) option may only be used for problems with single-phase liquid conditions throughout. The primary variables are (P, X_{sm}, X_3, T) for single-phase conditions and $(P, X_{sm}, S_g + 10, T)$ for two-phase conditions.

Primary variable # 2 (X_2) is used for NaCl, and denotes mass fraction X_s in the aqueous phase when no solid salt is present, while it is solid saturation plus ten ($S_s + 10$) in the presence of precipitated salt. The number 10 is added here to be able to determine whether or not a precipitated phase is present from the numerical range of the second primary variable. Solubility of NaCl in the gas phase is very small at the pressure and temperature conditions considered for

EWASG and has been neglected. During the Newton-Raphson iteration process, possible appearance or disappearance of a solid phase is checked, as follows. If no solid phase was present at the previous iteration, primary variable X_2 is known to denote salt mass fraction X_s in the aqueous phase, and the latest updated value is compared with the equilibrium solubility XEQ . If $S_s > XEQ$, precipitation starts, a small solid phase saturation is initialized as $S_s = 10^{-6}$, and the second primary variable is switched to $X_2 = S_s + 10$. If solid salt had been present at the previous iteration, EWASG checks whether $S_s = X_2 - 10$ is still larger than 0. If not, this indicates that the solid phase disappears; the second primary variable is then switched to dissolved salt mass fraction, and is initialized just below equilibrium solubility as $S_s = XEQ - 10^{-6}$.

Table 1. Summary of EWASG

<u>Components</u>	# 1: water # 2: NaCl # 3: NCG (CO ₂ , air, CH ₄ , H ₂ , N ₂ ; optional)
<u>Parameter choices</u>	(NK, NEQ, NPH, NB) = (3, 4, 3, 6) water, NaCl, NCG, nonisothermal (default) (3, 3, 3, 6) water, NaCl, NCG, isothermal (2, 3, 2, 6) water, NaCl, nonisothermal [†] (2, 2, 2, 6) water, NaCl, isothermal [†] molecular diffusion can be modeled by setting $NB = 8$
<u>Primary Variables</u>	single fluid phase (only liquid, or only gas) (P, X_{sm}, X_3, T) - (pressure, salt mass fraction X_s or solid saturation S_{s+10} , NCG mass fraction, temperature) two fluid phases (liquid and gas)& (P, X_{sm}, S_{g+10}, T) - (pressure, salt mass fraction X_s or solid saturation S_{s+10} , gas phase saturation S_{g+10} , temperature)

[†] the $NK = 2$ (no NCG) option may only be used for problems with single-phase liquid conditions throughout

& two-phase conditions may be initialized with variables ($T, X_{sm}, S_{g+10}, P_{NCG}$), or (T, X_{sm}, S_{g+10}, X_3), where P_{NCG} is the partial pressure of NCG, X_3 is mass fraction of NCG in the liquid phase; by convention, EWASG will assume the first primary variable to be pressure if it is larger than 370, otherwise it will be taken to be temperature; if the first primary variable is temperature, the last primary variable will be taken to mean mass fraction of NCG if it is less than 1, otherwise it will be taken to mean NCG partial pressure

Various options for EWASG can be selected through parameter specifications in data block **SELEC**, as follows.

SELEC keyword to introduce a data block with parameters for EWASG.

Record **SELEC.1**

Format (16I5)

IE(I), I=1,16

- IE (1)* set equal to 1, to read one additional data record (a larger value with more data records is acceptable, but only one additional record will be used by EWASG).
- IE (3)* allows choice of brine viscosity calculation.
- 0: after Phillips et al. (1981) (default).
 - 1: after Palliser and McKibbin (1998).
 - 2: after Mao and Sun (2006).
 - 3: after Potter (1978).
- IE (4)* allows choice of correlation for compressed brine density.
- 1: after Andersen et al. (1992).
 - 2: (void)
 - 3: Brine compressibility equal to water compressibility at the same reduced temperature.
 - 4: Brine compressibility equal to water compressibility at the same temperature.
 - 5: after Batzle and Wang (1992).
 - 6: after Driesner (2007) (default = 0).
- IE (8)* allows choice of NCG density and fugacity calculation.
- 0: original EWASG approach (default).
 - 1: NCG density according to Spycher and Reed (1988). Only for CO₂, CH₄, and H₂.

- 2: NCG density and gas-aqueous equilibrium according to Spycher and Reed (1988). Only for CO₂, CH₄, and H₂.
- IE (9)* allows choice of NCG enthalpy calculation in the aqueous phase.
- 0: original EWASG approach (default).
- 1: NCG enthalpy as a function of temperature.
- IE (10)* allows to turn vapor pressure lowering on/off.
- 0: VPL is off.
- 1: VPL is on.
- IE (11)* selects dependence of permeability on the fraction $\phi_f/\phi_0=(1-S_s)$ of original pore space that remains available to fluids.
- 0: permeability does not vary with ϕ_f .
- 1: $k/k_0=(1-S_s)^\gamma$, with $\gamma = FE (1)$ (record **SELEC.2**).
- 2: fractures in series, i.e., Eq. (2) with exponent 2 everywhere replaced by 3.
- 3: tubes-in-series, i.e., Eq. (2).
- IE (14)* allows choice of treatment of thermophysical properties as a function of salinity
- 0: full dependence (default).
- 1: vapor pressure independent of salinity.
- 2: vapor pressure and brine enthalpy independent of salinity.
- 3: no salinity dependence of thermophysical properties (salt solubility constraints are maintained).
- IE (15)* allows choice of correlation for brine enthalpy at saturated vapor pressure
- 1: after Michaelides (1981).
- 2: after Miller (1978). (obsolete)
- 3: after Phillips et al. (1981).
- 4: after Lorenz et al. (2000).
- 5: after Driesner (2007) (default = 0).

IE (16) allows choice of the type of NCG (default for *IE (16)*=0 is CO₂)

1: air

2: CO₂

3: CH₄

4: H₂

5: N₂

Record **SELEC.2** introduces parameters for functional dependence of permeability on solid saturation

Format (8E10.4)

FE(1), FE(2)

FE (1) parameter γ (for *IE (11)*=1); parameter ϕ_r (for *IE (11)* = 2, 3)

FE (2) parameter Γ (for *IE (11)* = 2, 3)

3. Sample Problems

3.1. Problem No. 1 (*dnh*) - Brine Density Calculation

This problem demonstrates the newly implemented brine correlations. Figure 3 shows the input file. Several element subproblems are simulated, which are entirely independent of each other (no flow connections between subproblems), except that being run together they all must go through the same sequence of time steps. Only a single time step (1E-8 sec) is computed to calculate the brine density at different initial salt mass fraction. The salt content approximately varies from 1 to 6 molal. $IE(4) = 6$ is specified in data block **SELEC** to compute the brine density according to Driesner (2007). Data block **OUTPU** is used to select the liquid density as a single print-out variable. Figure 4 shows the result using the input file shown in Figure 3, and Figure 5 shows the result using the option $IE(4) = 1$ and $IE(15) = 4$ (note that if only either the brine density ($IE(4)$) or enthalpy ($IE(15)$) is specified to use the Driesner's correlation, TOUGH3 internally assigns the other brine property uses the Driesner's correlation as well). The brine densities are slightly overestimated with $IE(4) = 1$, compared to those by Driesner (2007). A more comprehensive comparison between different approaches is shown in Battistelli (2012).

```

*dnh* CODE DEMONSTRATION: BRINE DENSITY CALCULATION
ROCKS-----1-----*-----2-----*-----3-----*-----4-----*-----5-----*-----6-----*-----7-----*-----8
TRANS          2650.          .50      1.E-14                                2.10      1000.

START-----1-----*-----2-----*-----3-----*-----4-----*-----5-----*-----6-----*-----7-----*-----8
-----*-----1 MOP: 123456789*123456789*1234 -----*-----5-----*-----6-----*-----7-----*-----8
PARAM-----1-----*-----2-----*-----3-----*-----4-----*-----5-----*-----6-----*-----7-----*-----8
      2      1          1100 30 000000000711
              -1.
          1.E-8

              800.E5              0.E-03              0.0              300.

RPCAP-----1-----*-----2-----*-----3-----*-----4-----*-----5-----*-----6-----*-----7-----*-----8
      3          .30          .05
      1          1.
ELEME-----1-----*-----2-----*-----3-----*-----4-----*-----5-----*-----6-----*-----7-----*-----8
F  1      5      1TRANS          1.

CONNE-----1-----*-----2-----*-----3-----*-----4-----*-----5-----*-----6-----*-----7-----*-----8

SELEC-----1-----*-----2-----*-----3-----*-----4-----*-----5-----*-----6-----*-----7-----*-----8
      1          6

OUTPU-----1-----*-----2-----*-----3-----*-----4-----*-----5-----*-----6-----*-----7-----*-----8
      1
DENSITY          2

```

Figure 3. Input file for brine density calculation.

```

INCON ---1---*---2---*---3---*---4---*---5---*---6---*---7---*---8
F 1
      800.E5          50.E-03          0.0          300.
F 2
      800.E5          100.E-03         0.0          300.
F 3
      800.E5          150.E-03         0.0          300.
F 4
      800.E5          200.E-03         0.0          300.
F 5
      800.E5          250.E-03         0.0          300.
F 6
      800.E5          300.E-03         0.0          300.
ENDCY---1---*---2---*---3---*---4---*---5---*---6---*---7---*---8

```

Figure 3. Input file for brine density calculation (continued).

```

"          ELEM", "          DEN L"
"          ", "          (KG/M**3) "
"TIME [sec] 0.10000000E-07"
"          F0001", 0.850375385003E+03
"          F0002", 0.892588655671E+03
"          F0003", 0.934449980570E+03
"          F0004", 0.976693351812E+03
"          F0005", 0.101981228215E+04
"          F0006", 0.106416641981E+04

```

Figure 4. Brine densities in CSV format based on **OUTPU** block shown in Figure 3 ($IE(4) = 6$).

```

"          ELEM", "          DEN L"
"          ", "          (KG/M**3) "
"TIME [sec] 0.10000000E-07"
"          F0001", 0.862412409614E+03
"          F0002", 0.899020589341E+03
"          F0003", 0.945347262013E+03
"          F0004", 0.998026105526E+03
"          F0005", 0.105714630679E+04
"          F0006", 0.112862620987E+04

```

Figure 5. Brine densities in CSV format when $IE(4) = 1$ and $IE(15) = 4$ is used.

3.2.Problem No. 2 (*rhbc*) - Production from a Geothermal Reservoir with Hypersaline Brine and CO₂

This problem examines production from a hypothetical geothermal reservoir with high salinity and CO₂. A single well produces at a constant rate of 65 kg/s from an infinite-acting reservoir in 1-D radial flow geometry. The reservoir is in two-phase conditions initially, with uniform initial conditions of $P = 60$ bar, $T = 275.55$ °C; other problem parameters are given in Table 2, and Figure 6 shows the TOUGH3 input file. The choices made with **SELEC**-data are: no vapor pressure lowering ($IE(10) = 0$), a tubes-in-series model for permeability reduction from precipitation ($IE(11) = 3$), full dependence of thermophysical properties on salinity ($IE(14) = 0$), Michaelides correlation for brine enthalpy ($IE(15) = 1$), and CO₂ as non-condensable gas ($IE(16) = 2$). The permeability-porosity relationship for the parameters used here ($IE(11) = 3$, $FE(1) = FE(2) = 0.8$) is shown in Figure 6.

Table 2. Parameters for production from a saline reservoir with CO₂.

Reservoir thickness	500 m
Permeability	$50 \times 10^{-15} \text{ m}^2$
Porosity	0.05
Relative permeability Corey curves with $S_{lr} =$ $S_{gr} =$	0.30 0.05
Rock grain density	2600 kg/m ³
Specific heat	1000 J/kg °C
Thermal conductivity	2.1 W/m °C
Initial conditions	
Temperature	275.55 °C
Gas saturation	0.45
Pressure	60.0 bar
NaCl mass fraction in liquid phase	0.30
CO ₂ partial pressure	14.79 bar
Wellblock radius	5 m
Production rate	65 kg/s

```

*rhbc* - 1-D radial flow problem for EWASG, with NaCl and CO2
MESHMAKER1-----2-----3-----4-----5-----6-----7-----8
RZ2D
RADII
  1
    5.
EQUID
  1          2.
LOGAR
  50          1.E2
LOGAR
  20          1.E3
EQUID
  1          0.0
LAYER-----1-----2-----3-----4-----5-----6-----7-----8
  1
    500.
ROCKS-----1-----2-----3-----4-----5-----6-----7-----8
POMED  2      2600.      .05  50.e-15  50.e-15  50.e-15      2.0  1000.0

  3      .30      .05
  1
    1.
SELEC-----2-----3-----4-----5-----6-----7-----8-----9-----10-----11-----12-----13-----14-----15-----16
  1
    .8  .8
    .... IE(16) = 2 chooses CO2 ....
MULTI-----1-----2-----3-----4-----5-----6-----7-----8
  3  4  3  6
START-----1-----2-----3-----4-----5-----6-----7-----8
-----1-----MOP:123456789012345678901234-----5-----6-----7-----8
PARAM-----1-----2-----3-----4-----5-----6-----7-----8
  1 100      100100 0000000000 40 0 3
    2.e6      -1.
    1.E4
    1.E-5      1.E00      1.E-7
    60.e5      .30      10.45      275.55
TIMES-----1-----2-----3-----4-----5-----6-----7-----8
  1  1
    5.e5
RPCAP-----1-----2-----3-----4-----5-----6-----7-----8
  3      .30      .05
  1
    1.
INCON-----1-----2-----3-----4-----5-----6-----7-----8
GENER-----1-----2-----3-----4-----5-----6-----7-----8
A1 lwel 1      MASS      -65.
ENDCY-----1-----2-----3-----4-----5-----6-----7-----8

```

Figure 6. TOUGH3 input file for constant-rate production from 1-D cylindrical reservoir.

Fluid withdrawal causes pressures to drop near the production well. Boiling of reservoir fluid gives rise to dilution of CO₂ in the gas phase and to increased concentrations of dissolved NaCl, which begins to precipitate when the aqueous solubility limit is reached. As the boiling front recedes from the well, solid precipitate fills approximately 10 % of the original void space (see Figure 7), causing permeability to decline to approximately 28 % of its original value.

Specifications of this problem (1-D radial geometry, uniform initial conditions, constant well rate) were chosen so that a similarity solution would be applicable, which should depend on radius R and time t only through the similarity variable $x = R^2/t$ (O'Sullivan, 1981). This similarity property should hold even when all complexities of two-phase flow with nonlinear relative permeabilities, CO₂ exsolution effects, salt precipitation, and associated porosity and permeability effects are taken into account. The agreement between results for two different times (5×10^5 and 2×10^6 seconds) when plotted as a function of the similarity variable shows that the similarity property holds very accurately for all thermodynamic variables (Figure 7). As a benchmark for proper code installation, we also provide printout for the first few time steps of the TOUGH3 run, Figure 8.

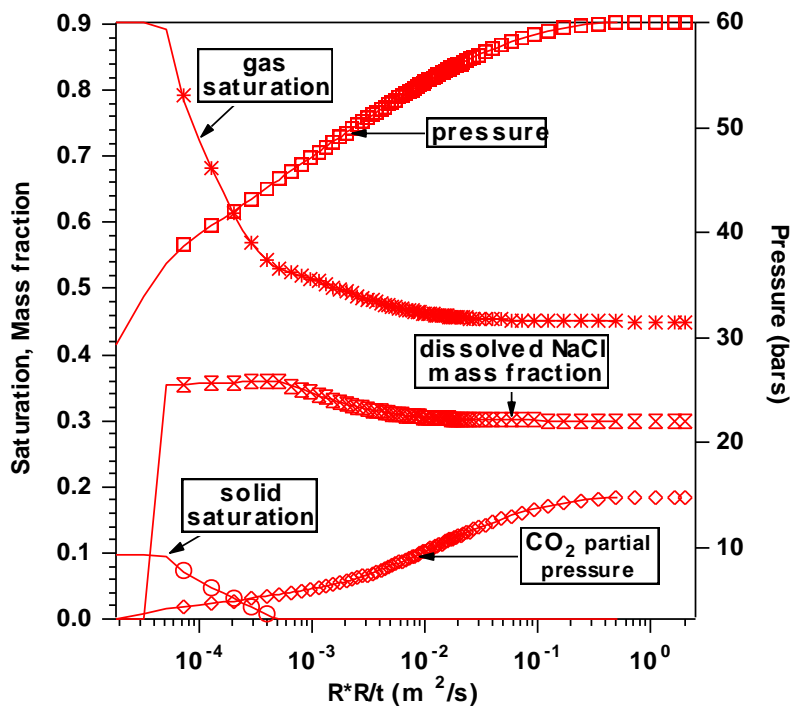

Figure 7. Simulated thermodynamic conditions for 1-D radial flow problem with salinity and non-condensable gas, plotted as a function of the similarity variable $x = R^2/t$. Results at 2×10^6 seconds are shown as lines, while the data at $t = 5 \times 10^5$ seconds are given as symbols.

```

...ITERATING... AT [ 1, 1] --- DELTEX = 0.100000E+05 MAX. RES. = 0.588437E+01 AT ELEMENT A1001 EQUATION 3
...ITERATING... AT [ 1, 2] --- DELTEX = 0.100000E+05 MAX. RES. = 0.173829E+01 AT ELEMENT A1001 EQUATION 3
...ITERATING... AT [ 1, 3] --- DELTEX = 0.100000E+05 MAX. RES. = 0.491418E-01 AT ELEMENT A1002 EQUATION 3
...ITERATING... AT [ 1, 4] --- DELTEX = 0.100000E+05 MAX. RES. = 0.134191E-03 AT ELEMENT A1001 EQUATION 3
A1001( 1, 5) ST = 0.100000E+05 DT = 0.100000E+05
...ITERATING... AT [ 2, 1] --- DELTEX = 0.100000E+05 MAX. RES. = 0.154112E+00 AT ELEMENT A1001 EQUATION 3
...ITERATING... AT [ 2, 2] --- DELTEX = 0.100000E+05 MAX. RES. = 0.105093E-01 AT ELEMENT A1001 EQUATION 3
...ITERATING... AT [ 2, 3] --- DELTEX = 0.100000E+05 MAX. RES. = 0.982143E-04 AT ELEMENT A1001 EQUATION 3
A1001( 2, 4) ST = 0.200000E+05 DT = 0.100000E+05
...ITERATING... AT [ 3, 1] --- DELTEX = 0.200000E+05 MAX. RES. = 0.890429E-01 AT ELEMENT A1001 EQUATION 1
...ITERATING... AT [ 3, 2] --- DELTEX = 0.200000E+05 MAX. RES. = 0.372304E-01 AT ELEMENT A1001 EQUATION 3
...ITERATING... AT [ 3, 3] --- DELTEX = 0.200000E+05 MAX. RES. = 0.206033E-03 AT ELEMENT A1001 EQUATION 3
A1002( 3, 4) ST = 0.400000E+05 DT = 0.200000E+05
...ITERATING... AT [ 4, 1] --- DELTEX = 0.400000E+05 MAX. RES. = 0.976097E-01 AT ELEMENT A1001 EQUATION 1
...ITERATING... AT [ 4, 2] --- DELTEX = 0.400000E+05 MAX. RES. = 0.101585E+01 AT ELEMENT A1001 EQUATION 3
...ITERATING... AT [ 4, 3] --- DELTEX = 0.400000E+05 MAX. RES. = 0.363453E-01 AT ELEMENT A1001 EQUATION 3
...ITERATING... AT [ 4, 4] --- DELTEX = 0.400000E+05 MAX. RES. = 0.680158E-04 AT ELEMENT A1001 EQUATION 3
A1001( 4, 5) ST = 0.800000E+05 DT = 0.400000E+05
...ITERATING... AT [ 5, 1] --- DELTEX = 0.400000E+05 MAX. RES. = 0.889134E-01 AT ELEMENT A1001 EQUATION 1
...ITERATING... AT [ 5, 2] --- DELTEX = 0.400000E+05 MAX. RES. = 0.129287E+00 AT ELEMENT A1001 EQUATION 3
...ITERATING... AT [ 5, 3] --- DELTEX = 0.400000E+05 MAX. RES. = 0.126046E-01 AT ELEMENT A1001 EQUATION 3
...ITERATING... AT [ 5, 4] --- DELTEX = 0.400000E+05 MAX. RES. = 0.118767E-04 AT ELEMENT A1001 EQUATION 3
A1001( 5, 5) ST = 0.120000E+06 DT = 0.400000E+05

```

Figure 8. Iteration sequence for first five time steps of the hypersaline reservoir problem.

References

- Andersen, G., A. Probst, L. Murray, and S. Butler, An accurate PVT model for geothermal fluids as represented by H₂O-CO₂-NaCl mixtures. Proceedings, Seventeenth Workshop on Geothermal Reservoir Engineering, 17:239–248. Stanford University, Stanford, Calif., January 29-31, 1992.
- Battistelli, A., C. Calore and K. Pruess. The Simulator TOUGH2/EWASG for Modeling Geothermal Reservoirs with Brines and Non-Condensable Gas, *Geothermics*, Vol. 26, No. 4, pp. 437 - 464, 1997.
- Battistelli, A. Improving the Treatment of Saline Brines in EWASG for the Simulation of Hydrothermal Systems. In: Finsterle et al. (Eds.), Proceedings of the TOUGH Symposium 2012. Report LBNL-5808E. Lawrence Berkeley National Laboratory, Berkeley, Calif., 2012.
- Batzle, M. and Wang, Z. 1992. Seismic properties of pore fluids. *Geophysics* 57 (11): 1396–1408.
- Driesner T., and C.H. Heinrich. The system H₂O–NaCl. Part I: Correlation formulae for phase relations in temperature–pressure–composition space from 0 to 1000°C, 0 to 5000 bar, and 0 to 1 XNaCl, *Geoch. Cosm. Acta*, 71, 4880–4901, 2007.
- Driesner T., The system H₂O–NaCl. Part II: Correlations for molar volume, enthalpy, and isobaric heat capacity from 0 to 1000°C, 1 to 5000 bar, and 0 to 1 XNaCl, *Geoch. Cosm. Acta*, 71, 4902–4919, 2007.
- Lorenz S., D. Maric, and C. Rirschl, Eine analytische Funktion zur Bestimmung der Enthalpie wässriger NaCl-Lösungen. Rapporto ISTec - A – 447, 2000.
- Mao S. and Z. Duan, The Viscosity of Aqueous Alkali-Chloride Solutions up to 623 K, 1,000 bar, and High Ionic Strength. *Int J Thermophys*, 30:1510–1523, 2006.
- Michaelides, E.E. Thermodynamic Properties of Geothermal Fluids, Geothermal Resources Council Transactions, Vol. 5, pp. 361 - 364, 1981.
- Miller, A.B. A Brine-Steam Properties Computer Program for Geothermal Energy Calculations, Lawrence Livermore National Laboratory Report UCRL-52495, Livermore, CA, June 1978.
- O’Sullivan, M.J., A Similarity Method for Geothermal Well Test Analysis, *Water Resour. Res.*, Vol. 17, No. 2, pp. 390 – 398, 1981.

- Palliser C., and R. McKibbin, A model for deep geothermal brines. I. T-P-X state-space description. *Transp. Por. Med.*, 33, 65-80, 1998.
- Phillips, S. L., A. Igbene, J.A. Fair, H. Ozbek, and M. Tavana, A technical databook for geothermal energy utilization, Lawrence Berkeley Laboratory Report LBL-12810, Berkeley, Calif., 1981.
- Potter R.W. II, Viscosity of Geothermal Brines. GRC Trans., Geothermal Resource Council, 2, 543-44, 1978.
- Spycher N.F. and M.H. Reed, Fugacity coefficients of H₂, CO₂, CH₄, H₂O and H₂O-CO₂-CH₄ mixtures: A virial equation treatment for moderate pressures and temperatures applicable to hydrothermal boiling. *Geochim. Cosmochim. Acta* 52, 739-749, 1988.
- Vaughan, P.J. Analysis of Permeability Reduction During Flow of Heated, Aqueous Fluid Through Westerly Granite, in C.F. Tsang (ed.), *Coupled Processes Associated with Nuclear Waste Repositories*, pp. 529 - 539, Academic Press, New York, 1987.
- Verma, A. and K. Pruess, Thermohydrologic Conditions and Silica Redistribution Near High-Level Nuclear Wastes Emplaced in Saturated Geological Formations, *J. of Geophys. Res.*, Vol. 93, No. B2, pp. 1159-1173, 1988.